



**Model no.: M02**

# **User's Manual**

M02-00150101

48011201231000

110609010008

©2015, Shenzhen General Measure Technology Stock Co., Ltd reserves all copyright.  
Without permission from Shenzhen General Measure Technology Stock Co., Ltd.,  
Any corporations or person must not copy, spread, record or translate into other  
language by any forms.

Our company reserved the right to update user's manual without additional  
notice to customers by reason of update, so please visit our website or contact  
with our service person to get update information.

Website: <http://www.szgmt.com.cn>

# CONTENTS

1 General Description.....	1
1.1 Functions and Characteristics .....	1
1.2 Front Panel.....	2
1.3 Technical Specifications.....	3
1.3.1 Common.....	3
1.3.2 Analog.....	4
1.3.3 Digital.....	4
2 Installation and Wiring.....	5
2.1 Connection of Power Supply.....	5
2.2 Connection of Load Cell.....	5
2.2.1 6-wired Connection.....	6
2.3 I/O terminals.....	7
2.4 Optional Expansion Board Output.....	8
2.4.1 Analog Output (Optional) ) .....	8
2.4.2 Serial Interface RS485 Output.....	11
2.4.3 Serial Interface RS232 Output.....	12

3 Calibration.....	13
3.1 Instruction.....	13
3.2 Flow Chart of Calibration.....	14
3.3 Millivolt Value Display.....	20
3.4 Calibration with Weights.....	20
3.5 Millivolt Calibration.....	20
3.6 Calibration Switch for Communication Interface.....	22
3.7 Explanation for Calibration Parameters.....	23
4 Working Parameters Setting.....	25
4.1 Flow Chart of Working Parameters Setting.....	25
4.2 Parameter Setting Method.....	27
4.3 Descriptions of Operation Parameters.....	28
4.4 Set point parameters.....	31
5 I/O Definition.....	33
5.1 I/O Definition.....	33
5.2 I/O testing.....	35
6 Serial Communication.....	36

6.1 r-Cont.....	37
6.2 r-SP1.....	37
6.2.1 Parameters Code Chart.....	37
6.2.2 Error Code Explanation.....	40
6.2.3 Command.....	40
6.3 tt TOLEDO.....	48
6.4 Cb920.....	49
6.5 rECont.....	50
6.6 rEReAD.....	51
6.7 Modbus.....	52
6.7.1 Modbus Communication Address.....	53
7 Password Input and Setting, Reset.....	60
7.1 Password Input.....	60
7.2 Password Setting.....	60
7.3 Factory Reset.....	62
8 Display Testing.....	64
9 Errors and Alarm Messages.....	65
10 Dimension of Indicator.....	66

## 1 General Description

M02 weighing indicator is specially designed for weight transmitting in industrial fields.

This indicator has the features of small volume, plenty communicating commands, stable performance, easy operation and practicability. It can be widely applied to concrete and bitumen mixing equipment, metallurgy furnace and converter, chemical industry and feed, etc. .

### 1.1 Functions and Characteristics

- Small volume, unique design, easy operation
- Applicable to all kinds of resistance strain gauge bridge load cell
- Front panel numerical calibration
- Multilevel of digital filter
- Automatic zero -tracking
- Automatically zero when powered on
- 4 set points
- 1 input and 2 outputs
- Serial communication interface:RS232 or RS485
- Calibration via serial interface
- Optional interfaces: Analog output, serial interface

## 1.2 Front Panel

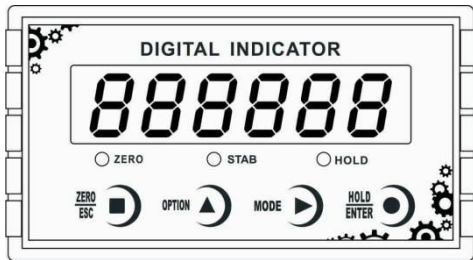

### M02 Front panel

**Main Display:** 6 digits, for displaying weight and the information of parameters.

**Status Indicator Lamp:**

- **ZERO:** Light on when present weight is within  $0 \pm 1/4d$ .
- **STAB:** Light on when changes of weight values are within the range of motion detecting during motion detecting time.
- **HOLD:** Light on when indicator displays the value of D/A output.

**Keypad:**



: Zero/Esc, Used to exit from current operation or go previous.



: Used to scroll optional values of parameter and to make flashing digit increase 1 while data inputting.



: Function Selecting Key, To make flashing position move to the right digit when data inputting.



: Confirming Key. Used to confirm present operation.

## 1.3 Technical Specifications

### 1.3.1 Common:

Power supply: **DC24V±5%**

Working temperature: **-10~40℃**

Max humidity: **90%R.H without dew**

Power consumption: **About 10W**

Dimension: **110×89×60 (mm)**



### 1.3.2 Analog:

Load cell power: **DC5V 200mA (MAX)**

Input impedance: **10MΩ**

Zero steady range: **0.00~12mV(Load cell 3mV/V)**

Input sensitivity: **0.1uV/d**

Input range: **0.00~15mV(Load cell 3mV/V)**

Transfer mode: **Sigma - Delta**

A/D conversion speed: **15, 30, 60, 120, 480, 960 times/sec**

Non-linearity: **0.01% F.S**

Gain drift: **10PPM/°C**

Display Precision: **1/100,000**

### 1.3.3 Digital:

Weight display: **6 digits red high-brightness LED**

Minus display: **"-"**

Overload display: **"OFL"**

Decimal point: **5 kinds (optional)**

Function keys: **4 keys soniferous keypad**

## 2 Installation and Wiring

### 2.1 Connection of Power Supply

M02 weighing indicator connects DC24V power supply as follows:

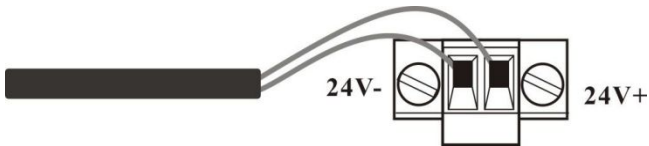

Power supply connection

### 2.2 Connection of Load Cell

M02 weighing indicator connects bridge type resistance strain gauge load cells by 6 wires or 4 wires as follows. When you use 4-wired load cells, you must bridge the SN+ with EX+ and bridge the SN- with EX-.

The signal definition of each port of the load cell connector is as follows:

**EX+:** Excitation+    **EX-:** Excitation-    **SN+:** Sense+    **SN-:** Sense-    **SIG+:** Signal+    **SIG-:** Signal-

<b>6 wires</b>	<b>EX+</b>	<b>SN+</b>	<b>EX-</b>	<b>SN-</b>	<b>SIG+</b>	<b>SIG-</b>	<b>Shield</b>
<b>4 wires</b>	<b>EX+</b>		<b>EX-</b>		<b>SIG+</b>	<b>SIG-</b>	<b>Shield</b>

### 2.2.1 6 wires connection

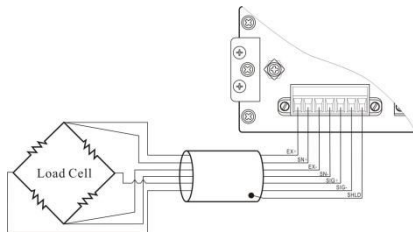

**Note:**

1. As load cell output sensitive analog signal, please use shield cable to separate with other cables, especially AC power.
2. 4 wires connection is suitable for short distance and stable temperature or low precision field, otherwise use 6 wires connection.
3. For more load cells parallel connection, their sensitivity (mV/V) should be same.

## 2.3 I/O terminals

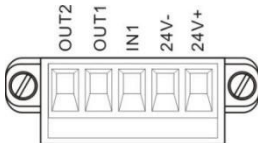

I/O tolerant definition as follows:

Output		Input	
OUT1	Stable	IN1	Reset all
OUT2	OFL		

Indicator input terminal connection:

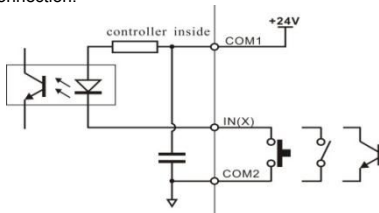

Indicator input terminal connection:

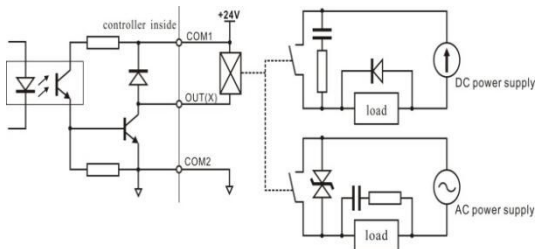

## 2.4 Optional Expansion Board Output

M02 weighing indicator supports analog output, RS232 or RS485 as optional output function, please confirm it when place orders.

### 2.4.1 Analog Output (Optional)

At normal displaying status, press **HOLD** **ENTER**  to check the analog output.

The definition of analog output as below:

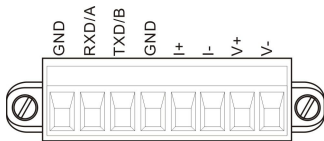

The definition of analog output:

**V+**: voltage-output+, **V-**: voltage-output-

**I+**: current-output +, **I-**: current-output -

**Analog output two types:**

- 1) **Voltage output: 0-5V/0-10V is optional .**
- 2) **Electric current output: 4-20mA/0-20mA/0-24mA is optional.**
- 3) **User-define function, users can define analog output type and output range.**

**The analog output has been calibrated before the delivery of the indicators, so users do not need to make calibration. If analog output is abnormal, users can calibrate by themselves as follows: (Suggestion: please calibrate under the instruction of professionals)**

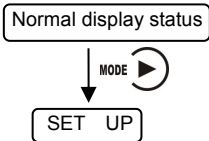

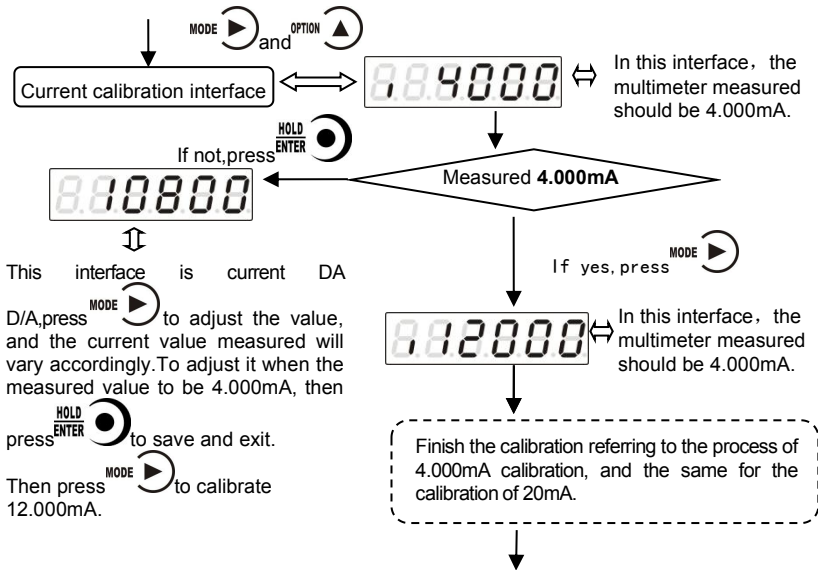

Note: only support calibration under current mode. 4 points must be finished for current calibration.





This interface is the highest point calibration of analog output.

In the interface of highest point calibration, press  to enter into analog display value interface, the display will be 5 digits (initial value is **24000**, means **24.000mA**), press  to input the value measured by the multimeter.

Note: Analog output calibration, highest point must be calibrated.

#### 2.4.2 Serial Interface RS485 Output

Serial Interface RS485 output is optional, please refer to chapter 6.0 for communication protocol.

##### RS485 serial interface connection:

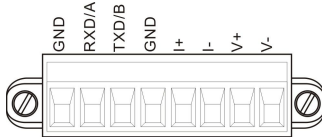



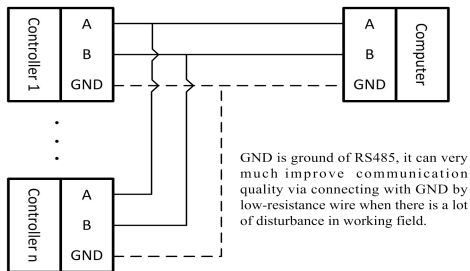

### 2.4.3 Serial Interface RS232 output (Optional)

RS232 serial interface connection:

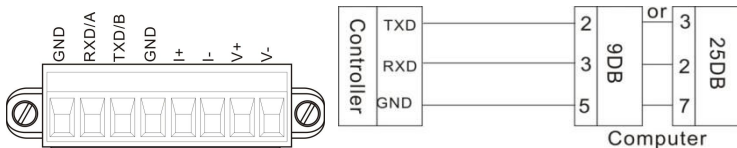

### 3 Calibration

#### 3.1 Instruction

(1) Calibration procedure must be executed when a M02 indicator is put in use at the first time, the preset parameters may no longer meet the user's needs, and any part of the weighing system was changed. Position of decimal point, minimum division, maximum capacity, zero, and gain can be set and confirmed through calibration.

(2) If you want to set only one parameter, please press  to save parameter's

value and then press  to exit.

(3) Please see section **3.7** for parameters' instruction.

(4) Please record each value in the blank table in section 3.4 during calibration for the emergency use in future.

(5) See chapter **9** for error alarm message that may be displayed during calibration.

### 3.2 Flow Chart of Calibration

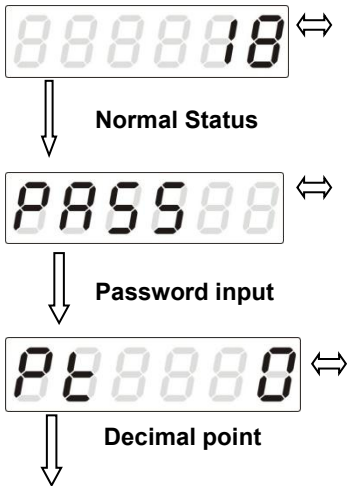



1. Under this status, press  (twice), indicator will display **CAL**, then

press  to enter password input.

2. After password is input, the indicator will display **CALON** for one second, then go to next step.

3. Press  to select a desired value for decimal point among **0**, **0.0**, **0.00**, **0.000** and **0.0000**, and then

press  to save it and enter next step. If there's no need to change the value,

press  directly to enter next step.



Min. division







Max. capacity



Millivolt value display



4. Press  to select a desired value for min. division among **1,2,5,10,20** and **50**, and then to save it and enter next step.  
If there's no need to change the value, then press  directly to enter next step.

5. Input max. capacity ( $\leq \text{min. division} \times 100000$ ), press  to save it and enter next step.  
If there's no need to change the value, then press  directly to enter next step.

6. Under this status, press  to enter zero calibration.  
Display value near the output value in millivolt between **SIG+**/**SIG-** of load cell.  
See section [3.3](#) for details about this function.



**Zero calibration**



7. Unloaded scale first, when **STAB** lamp is on,

press  to finish zero calibration.

If there's no need to calibrate zero,

press  directly to enter gain calibration.

8. The process of gain calibration is as follows. If there's no need to do gain calibration, press



directly to enter serial ports calibration switch setting.

Gain Calibration

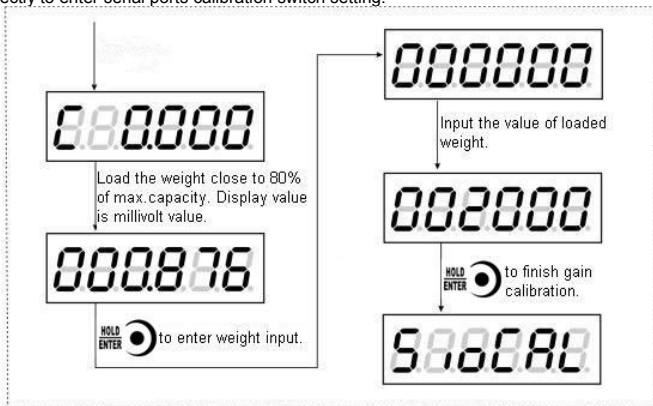





Serial ports  
calibration switch

Password setting



Normal status



9. Press  to enter setting interface,  
press  to choose the switch position,  
press  to set password. If don't need to set  
switch position, then press  to enter password  
setting.
10. See section 7.2 for reference to set password.  
If there's no need to set password,  
press  directly to go back to normal  
status.

### 3.3 Millivolt Value Display

This function is mainly used for system test, position-error test for weighing mechanism and linearity test for load cell.

#### 1. System Test

(1) If display data changes with loaded weight changes, it shows that connection of load cell is correct and weighing mechanism works well.

(2) If display value is OFL (or -OFL), it means that loaded weight on load cells is too large (or too small). Please unload the weight (or load more), if display value is still OFL (or -OFL), the possible reasons are as follows:

- a. There is something wrong with weighing mechanism, please check and clear.
- b. The connection of load cell is incorrect, please check and clear.
- c. Load cells may be damaged, please replace.

#### 2. Position-error Test for Weighing Mechanism

Load a same weight on each corner of weighing mechanism and record displayed millivolt value respectively. If differences among these values are obvious, please adjust weighing mechanism.

#### 3. Linearity Test for Load Cell

Load same weight for several times, and record displayed value every time. If one or two values are obviously much larger or smaller than any others, it means that the linearity of load cell is bad.

**\*NOTE: You must use  to zero display data before weight is loaded for each time.**



### 3.4 Calibration with Weights

During calibration with weight, please record the zero millivolt value, gain millivolt value and the loaded weight value in the blank table below. If it is not convenient to load a weight to calibrate, these values can be used for calibration without weights.

	<b>Zero millivolt value(mV)</b>	<b>Gain millivolt value(mV)</b>	<b>Loaded Weight</b>	<b>Date</b>	<b>Remarks</b>
<b>1</b>					
<b>2</b>					
<b>3</b>					
<b>4</b>					
<b>5</b>					

### 3.5 Millivolt Calibration

When it is not convenient to load a weight to calibrate, alibration can be done without weights using recorded data in the table in section 3.4.

However, this method is just used for some emergencies, it will make calibration result incorrect if load cells, or indicator has been replaced.

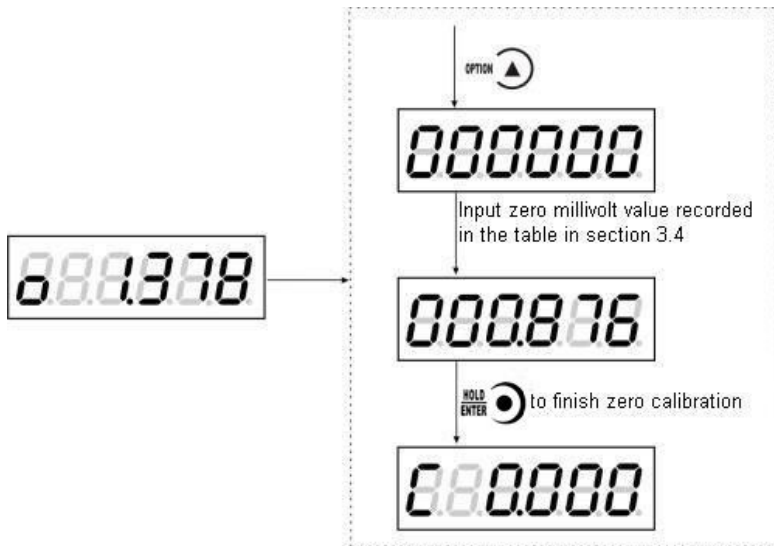

## Gain Calibration

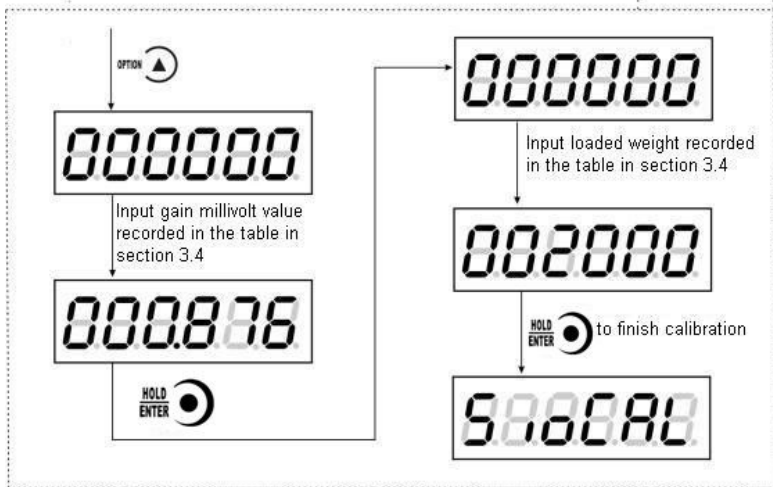

### 3.6 Calibration Switch for Communication Interface

When calibrate the transmitter through serial port( Rs、 SP1 or Modbus), must set to “ON” status for the calibration switch for communication interface.

### 3.7 Explanation for Calibration Parameters

Symbol	Parameter	Types	Value of parameter	Default
<b>Pt</b>	Decimal Point	<b>5</b>	<b>0 0.0 0.00 0.000 0.0000</b>	<b>0</b>
<b>1d</b>	Min. Division	<b>6</b>	<b>1 2 5 10 20 50</b>	<b>1</b>
<b>CP</b>	Max. Capacity		$\leq \text{Min. Division} \times 100000$	<b>10000</b>
<b>t</b>	Millivolt Value			
<b>o</b>	Zero			
<b>C</b>	Gain			
<b>SIOCAL</b>	Switch for Calibration via serial interface			<b>OFF</b>
<b>PASS</b>	Password Setting			<b>000000</b>

## Log Table for Calibration Parameters

Parameter	Calibrated Value	Date	Remarks
Decimal Point			
Min. Division			
Max. Capacity			
Load cell sensitivity			
Password			

## 4 Working Parameters Setting

### 4.1 Flow Chart of Working Parameters Setting

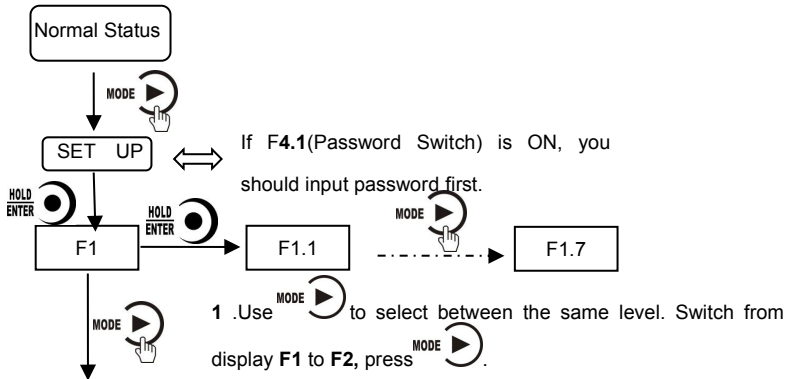

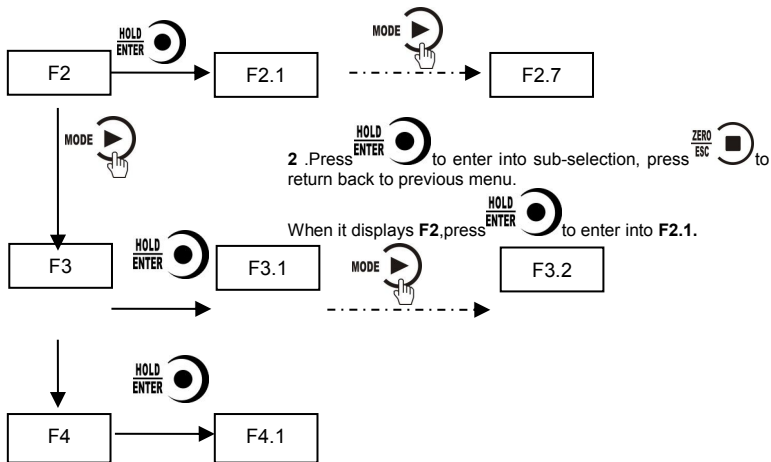



## 4.2 Parameter Setting Method

M02 has 2 kinds of working parameters: Selection type and data type. For

selection type parameters, press  to choose. For data type parameter in

parameter interface, press  to choose digit position, press  se value.

### Selection:

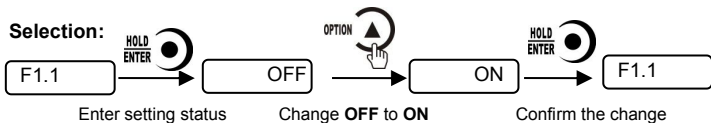

### Data:

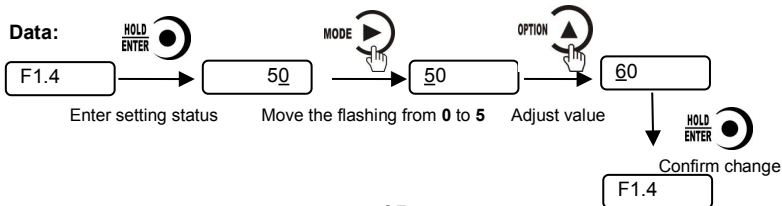



### 4.3 Descriptions of Operation Parameters

Code	Default	Description
<b>F1</b>	<b>Null</b>	<b>The first major term of working parameter.</b>
<b>F1.1</b>	<b>OFF</b>	Switch for Auto-Zeroing when power-on, OFF: disabled ON: enabled
<b>F1.2</b>	<b>0</b>	Zero-tracking Range (0~9d optional) . This parameter is for automatic calibration, disabled when is set "0".
<b>F1.3</b>	<b>1</b>	Motion Detecting Range (1~9d optional)
<b>F1.4</b>	<b>50</b>	Zeroing Range (00%~99% of Maximum capacity)
<b>F1.5</b>	<b>5</b>	Digital filtering parameter: (1-9 as optional) 0: without filtering 9: strongest digital filtering
<b>F1.6</b>	<b>0</b>	Stable filter parameter (the second filter based on the first filter) : (1-9 as optional) 0: without filtering 9: strongest digital filtering
<b>F1.7</b>	<b>0</b>	A/D conversion rate: 120,480,960,15,30,60 as optional

<b>F2</b>	<b>Null</b>	<b>The second major term of working parameter.</b>
<b>F2.1</b>	<b>01</b>	Scale no., indicator no.
<b>F2.2</b>	<b>9600</b>	Baud rate of serial port
<b>F2.3</b>	<b>Cb920</b>	Serial ports communication mode: <b>Modbus-RTU: MODBUS RTU mode;</b> <b>r-Cont:SP1 continuous mode;</b> <b>r-SP1: SP1 command mode;</b> <b>tt:TOLEDOcontinuous mode;</b> <b>Cb920: Cb920 continuous mode.</b> <b>rE-Cont:rE continuous mode;</b> <b>rE- rEAd:rEcommand mode;</b>
<b>F2.4</b>	<b>7-E-1</b>	<b>Data format:</b> <b>7-E-1: 7 data bits, even parity check, 1 stop bit;</b> <b>7-O-1: 7data bits, odd parity check, 1 stop bit;</b> <b>8-E-1: 8 data bits, even parity check, 1 stop bit;</b> <b>8-O-1: 8 data bits, odd parity check, 1 stop bit;</b> <b>8-n-1: 8 data bits, no parity check, 1 stop bit;</b> <b>8-n-2: 8 data bits, no parity check, 2 stop bit;</b>

<b>F2.5</b>	<b>HiLo</b>	<b>MODBUS dual-byte register storage turn , Hi Lo :</b> High byte in the front, low byte at the back; <b>Lo Hi:</b> Low byte in the front, high byte at the back
<b>F2.6</b>	<b>nonE</b>	Cont mode automatic sending time interval
<b>F2.7</b>	<b>0</b>	<b>tt(TOLEDOcontinuous mode)</b> If send the checksum. <b>0:</b> not send, <b>1:</b> send.
<b>F3</b>	<b>Null</b>	<b>The third major term of working parameter.</b> (For analog output only)
<b>F3.1</b>	<b>0-5</b>	<b>Analog output:</b> <b>4-20: 4-20mA</b> <b>0-20: 0-20mA</b> <b>0-24: 0-24mA</b> <b>0-5: 0-5V</b> <b>0-10: 0-10V</b> <b>I_out:</b> Current customized <b>V_out:</b> Voltage customized In customized mode, <b>F3.2-F3.5</b> parameters available
<b>F3.2</b>	<b>3920</b>	Minimum output
<b>F3.3</b>	<b>4000</b>	Zero point output

<b>F3.4</b>	<b>20000</b>	Maximum capacity output
<b>F3.5</b>	<b>20020</b>	Maximum output
<b>F4</b>	<b>Null</b>	<b>The fourth major term of working parameter.</b>
<b>F4.1</b>	<b>OFF</b>	Parameters password setting switch.
<b>F4.2</b>	<b>000000</b>	Parameters password setting:Valid when F4.1 is ON

#### 4.4 Set point parameters

<b>Code</b>	<b>Default</b>	<b>Description</b>
<b>P1-P4</b>	<b>Null</b>	<b>The first term of working parameters</b>
<b>PX.1</b>	<b>OFF</b>	Change of state if need stable
<b>PX.2</b>	<b>0.0</b>	Change of state minimum duration
<b>PX.3</b>	<b>P1.3=1</b> <b>P2.3=5</b> <b>P3.3=0</b> <b>P4.3=0</b>	Condition of validity: 0: forbid; 1: <; 2: <= 3: ==; 4: >= 5: >;

		6: !=; compare to minimum value 7: _<>_outside the range, need to set 2 edge value 8: =<__>=inside the range, need to set 2 edge value 9: external trigger. If it's IO, do 1 state change for 1 trigger, if it's command, then decide according to valid or invalid command.
<b>PX.4</b>	<b>0</b>	Set value 1 (Set value 1 and set value 2, choose the minimum to compare)
<b>PX.5</b>	<b>0</b>	Set value 2

Set point has 4 major terms which are user defined.

## 5 I/O Definition

### 5.1 I/O Definition

Output/Input code table:

Output		
Code	Definition	Description
<b>O0</b>	None	No definition
<b>O1</b>	Stable	Effective output in stable status.
<b>O2</b>	Overflow	Effective output when overflow.
<b>O3</b>	Sp1	Effective output when set point <b>1</b> status output.
<b>O4</b>	Sp2	Effective output when set point <b>2</b> status output.
<b>O5</b>	Sp3	Effective output when set point <b>3</b> status output.
<b>O6</b>	Sp4	Effective output when set point <b>4</b> status output.

<b>Input</b>		
<b>Code</b>	<b>Definition</b>	<b>Description</b>
<b>I0</b>	None	No definition
<b>I1</b>	Zeroing	Effective input for zeroing, pulse input signals
<b>I2</b>	Sp1	If this signal is valid, Sp1 status will be regarded as invalid. Output valid state when comparison condition turns to invalid, and be effective again.
<b>I3</b>	Sp2	If this signal is valid, Sp2 status will be regarded as invalid. Output valid state when comparison condition turns to invalid, and be effective again.
<b>I4</b>	Sp3	If this signal is valid, Sp3 status will be regarded as invalid. Output valid state when comparison condition turns to invalid, and be effective again.
<b>I5</b>	Sp4	If this signal is valid, Sp4 status will be regarded as invalid. Output valid state when comparison condition turns to invalid, and be effective again.



I6	Reset all	Reset all paramater value when this signal is valid.
----	-----------	--



## 5.2 I/O testing

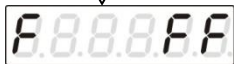

Normal Status



Under weighing status, press  (5 times), then display **TESTio**, press  enter into I/O testing interface.

Press  **OUT1** status flash, press  **OUT2** status flash.

This interface shows: **IN1** input valid, **OUT1** output valid.



## 6 Serial Communication

M02 has RS232 or RS485 as optional to realize communication with upper computer. Support r-Cont、r-SP1、Modbus(bus)、tt TOLEDO、Cb920、rECont protocols and rErEAD protocol.

Serial communication terminal please refer to chapter 2.4.2、2.4.3. Baud rate and communication format setting please refer to F2.2、F2.3 and F2.4.

※Under main display (display weight value), long press  to enter into serial communication checking interface, it will display '-----' if no communication, and '-----' will flash if there's communication.

### 6.1 r-Cont

Indicator will send weighing data to host computer without command.

Data Format:

STX	Scale no.	Channel no.	Status	Value	CRC	CR	LF
-----	-----------	-------------	--------	-------	-----	----	----

Here:

**STX** —— 1bit, start character **02H**

**Scale no.** —— 2bits, **00~99**

**Status** —— 2bits, high byte:**40H**; low byte definition as follows:

D6	D5	D4	D3	D2	D1	D0
Null	Null	G./N. weight	+/-	Zero point	OFL	Stable
<b>1</b>	<b>0</b>	<b>0</b>	<b>0:</b> + <b>1:</b> -	<b>0:</b> non/zero <b>1:</b> zero	<b>0:</b> normal <b>1:</b> OFL	<b>0:</b> not stable <b>1:</b> stable

Weight Value — 6 bits; when weight is+ (-) overflow,return to“space space **OFL** space”

**CRC** — 2 bits,check sum

**CR** — 1 bit, **0DH**

**LF** — 1 bit, **0AH**

For example:

**02 30 31 31 40 4120 20 20 37 30 30 32 34 0D 0A**

Means: stable,positive data,present weight **700**

## 6.2 r-SP1

Code : **ASCII**

Operation code supported: **W**, write; **R**, read; **C**, calibrate; **O**, zero

### 6.2.1 Parameters Code Chart

Operation code	Para. code	Para. Name	number of character
<b>R</b>	<b>WT</b>	Read current status	<b>8</b>

		and weight	
<b>R</b>	<b>SP</b>	Read set point status	<b>4</b>
<b>W</b>	<b>DC</b>	Write mini. Division and max. capacity	<b>8</b>
<b>R/W</b>	<b>PT</b>	Decimal point digit	<b>1</b>
<b>R</b>	<b>DD</b>	Minimum division	<b>2</b>
<b>R</b>	<b>CP</b>	Maximum capacity	<b>6</b>
<b>R/W</b>	<b>AC</b>	Auto. Zeroing switch	<b>1</b>
<b>R/W</b>	<b>TR</b>	Zero tracking range	<b>1</b>
<b>R/W</b>	<b>MR</b>	Stable range	<b>1</b>
<b>R/W</b>	<b>ZR</b>	Zeroing range	<b>2</b>
<b>R/W</b>	<b>FL</b>	digital filtering para.	<b>1</b>
<b>R/W</b>	<b>VC</b>	steady filtering	<b>1</b>
<b>R/W</b>	<b>AD</b>	AD sample rate	<b>1</b>
<b>R</b>	<b>PO</b>	Set point output status	<b>4</b>
<b>R/W</b>	<b>P1M~P4M</b>	Set point to judge if need stability	<b>1</b>
<b>R/W</b>	<b>P1T~P4T</b>	Set point minimum duration time	<b>3</b>
<b>R/W</b>	<b>P1F~P4F</b>	Set point comparison condition to judge	<b>1</b>
<b>R/W</b>	<b>P1L~P4L</b>	Set point lower edge value to judge	<b>6</b>
<b>R/W</b>	<b>P1H~P4H</b>	Set point upper edge value to judge	<b>6</b>

R	AM	Absolute millivolt	7: <b>D6D5D4D3D2D1D0</b> ; D6:++;D5-D0: corresponding ASCII for 6 digits millivolt,Decimal point is fixed to 3 digits
R	RM	Relative zero point on millivolt	7: <b>D6D5D4D3D2D1D0</b> D6 : +/-;D5-D0:corresponding ASCII for 6 digits, Decimal point is fixed to 3 digits
C	ZY	Zero calibration with weight	
C	ZN	Zero calibration without weight	6
C	GY	Gain calibration with weight	6
C	GN	Gain calibration without weight	12
O	CZ	Zero clearing command	
O	P1S~P4S	Setting the corresponding set point	Valid when 9,command valid when external trigger and 1 status change for 1 external Trigger
O	P1C~P4C	Clear the corresponding set point	
R	ID	Read ID No.	6

### 6.2.2 Error Code Explanation

- 1: CRC check error
- 2: Operation code error
- 3: Parameters code error
- 4: Write data error
- 5: Operation invalid
- 6: Channel no. error

Note: Default channel no. of this indicator : **1 (31H)**

### 6.2.3 Command

Indicator will send weighing data to host computer after received command.

#### 6.2.3.1 Host computer read present status

Send command:

<b>STX</b>	Scale no.	Channel No.	<b>R</b>	<b>WT</b>	<b>CRC</b>	<b>CR</b>	<b>LF</b>
------------	-----------	-------------	----------	-----------	------------	-----------	-----------

Correct response:

<b>STX</b>	Scale no.	Channel No.	<b>R</b>	<b>WT</b>	Status	Value	<b>CRC</b>	<b>CR</b>	<b>LF</b>
------------	-----------	-------------	----------	-----------	--------	-------	------------	-----------	-----------

Wrong response:

<b>STX</b>	Scale no.	Channel No.	<b>R</b>	<b>WT</b>	<b>E</b>	Error code	<b>CRC</b>	<b>CR</b>	<b>LF</b>
------------	-----------	-------------	----------	-----------	----------	------------	------------	-----------	-----------

Here :

**STX** — 1bit, start character, **02H**

**R** — 1 bit, **52H**

**WT** — 2 bit, **57H 54H**

**E** — 1 bit, **45H**

Status — 2bits, high byte: **40H**; low byte definition as follows:

D6	D5	D4	D3	D2	D1	D0
Null	Null	G./N. weight	+/-	Zero point	OFL	Stable
<b>1</b>	<b>0</b>	<b>0</b>	<b>0</b> : + <b>1</b> : -	<b>0</b> : non/zero <b>1</b> : zero	<b>0</b> : normal <b>1</b> : OFL	<b>0</b> : not stable <b>1</b> : stable

Weight Value — 6 bits; when weight is+ (-) overflow,return to“space space **OFL** space”

For example:

**02 30 31 31 52 57 54 30 31 0D 0A**

Correct response : **02 30 31 31 52 57 54 40 4130 30 33 37 35 33 33 36 0D 0A**  
(**stable**present value **3753**)

Wrong response: **02 30 31 31 52 57 54 45 31 31 39 0D 0A** (CRC check error)

### 6.2.3.2 Read other parameters

Send command:

<b>STX</b>	Scale no.	Channel No.	<b>R</b>	<b>Para. code</b>	<b>CRC</b>	<b>CR</b>	<b>LF</b>
------------	-----------	-------------	----------	-------------------	------------	-----------	-----------

Correct response:

<b>STX</b>	Scale no.	Channel No.	<b>R</b>	<b>Para. code</b>	Value	<b>CRC</b>	<b>CR</b>	<b>LF</b>
------------	-----------	-------------	----------	-------------------	-------	------------	-----------	-----------

Wrong response:

<b>STX</b>	Scale no.	Channel No.	<b>R</b>	<b>Para. code</b>	<b>E</b>	Error code	<b>CRC</b>	<b>CR</b>	<b>LF</b>
------------	-----------	-------------	----------	-------------------	----------	------------	------------	-----------	-----------

Here:

**Para. Value**—— 1bit

**Para. code**——2 bits,

For example:

**02 30 31 31 524D52 3839 0D 0A**

Correct response: **02 30 31 31 52 4D 52 36 34 33 0D 0A** (stable range: 6)

Wrong response:**02 30 31 31 53 4D 52 45 32 30 39 0D 0A** (Operation code error)

### 6.2.3.3 Write max. Capacity and min. Division

Send command:

<b>STX</b>	Scale no.	Channel No.	<b>W</b>	<b>DC</b>	Division value	Max. capacity	<b>CRC</b>	<b>CR</b>	<b>LF</b>
------------	-----------	-------------	----------	-----------	----------------	---------------	------------	-----------	-----------

Correct response:

<b>STX</b>	Scale no.	Channel No.	<b>W</b>	<b>DC</b>	<b>O</b>	<b>K</b>	<b>CRC</b>	<b>CR</b>	<b>LF</b>
------------	-----------	-------------	----------	-----------	----------	----------	------------	-----------	-----------

Wrong response:

<b>STX</b>	Scale	Channel	<b>W</b>	<b>DC</b>	<b>E</b>	Error code	<b>CRC</b>	<b>CR</b>	<b>LF</b>
------------	-------	---------	----------	-----------	----------	------------	------------	-----------	-----------

	no.	No.							
--	-----	-----	--	--	--	--	--	--	--

Here:

**DC**——2 bits, **44H 43H**

**O**——1 bit, **4FH**

**K**——1 bit, **4BH**

Division value——2 bits, **1/2/5/10/20/50**

Max. capacity——6 bits

For example:

**02 30 31 31 57 44 43 30 35 30 31 30 30 30 30 36 30 0D 0A**(division value 5, Max capacity 10000)

Correct response: **02 30 31 31 57 44 43 4F 4B 32 34 0D 0A**

Wrong response: **02 30 31 31 57 44 43 45 35 39 32 0D 0A** (Operation can't execute)

#### 6.2.3.4 Write other parameters

Send command:

<b>STX</b>	Scale no.	Channel No.	<b>W</b>	<b>Para. code</b>	Para. value	<b>CRC</b>	<b>CR</b>	<b>LF</b>
------------	-----------	-------------	----------	-------------------	-------------	------------	-----------	-----------

Correct response:

<b>STX</b>	Scale no.	Channel No.	<b>W</b>	<b>Para. code</b>	<b>O</b>	<b>K</b>	<b>CRC</b>	<b>CR</b>	<b>LF</b>
------------	-----------	-------------	----------	-------------------	----------	----------	------------	-----------	-----------

Wrong response:

<b>STX</b>	Scale	Channel	<b>W</b>	<b>Para.</b>	<b>E</b>	Error	<b>CRC</b>	<b>CR</b>	<b>LF</b>
------------	-------	---------	----------	--------------	----------	-------	------------	-----------	-----------



	no.	No.		code		code			
--	-----	-----	--	------	--	------	--	--	--

For example:

**02 30 31 31 157 5A 52 35 30 30 38 0D 0A** (Write zeroing range to 50)

Correct response: **02 30 31 31 57 5A 52 4F 4B 36 31 0D 0A**

Wrong response: **02 30 31 31 57 5A 53 45 33 32 38 0D 0A** (Para. Code error)

### 6.2.3.5 Calibration Zero

#### 1) Calibrate zero as per current weight (with weight)

Send command:

<b>STX</b>	Scale no.	Channel No.	<b>C</b>	<b>ZY</b>	<b>CRC</b>	<b>CR</b>	<b>LF</b>
------------	-----------	-------------	----------	-----------	------------	-----------	-----------

Correct response:

<b>STX</b>	Scale no.	Channel No.	<b>C</b>	<b>ZY</b>	<b>O</b>	<b>K</b>	<b>CRC</b>	<b>CR</b>	<b>LF</b>
------------	-----------	-------------	----------	-----------	----------	----------	------------	-----------	-----------

Wrong response:

<b>STX</b>	Scale no.	Channel No.	<b>C</b>	<b>ZY</b>	<b>E</b>	Error code	<b>CRC</b>	<b>CR</b>	<b>LF</b>
------------	-----------	-------------	----------	-----------	----------	------------	------------	-----------	-----------

Here:

**Z**—1 bit, **5AH**

**Y**—1 bit, **59H**

For example:

**02 30 31 31 435A 59 39 34 0D 0A**

Correct response: **02 30 31 31 43 5A 59 4F 4B 34 38 0D 0A**

Wrong response: **02 30 31 34 43 5A 59 45 36 32 30 0D 0A** (channel no. error)

#### 2) Input millivolt calibration zero in the chart (without weight)

Send command:

<b>STX</b>	Scale no.	Channel No.	<b>C</b>	<b>ZN</b>	Zero millivolt value	<b>CRC</b>	<b>CR</b>	<b>LF</b>
------------	-----------	-------------	----------	-----------	----------------------	------------	-----------	-----------

Correct response:

<b>STX</b>	Scale no.	Channel No.	<b>C</b>	<b>ZN</b>	<b>O</b>	<b>K</b>	<b>CRC</b>	<b>CR</b>	<b>LF</b>
------------	-----------	-------------	----------	-----------	----------	----------	------------	-----------	-----------

Wrong response:

<b>STX</b>	Scale no.	Channel No.	<b>C</b>	<b>ZN</b>	<b>E</b>	Error code	<b>CRC</b>	<b>CR</b>	<b>LF</b>
------------	-----------	-------------	----------	-----------	----------	------------	------------	-----------	-----------

Here:

**ZN**——2 bits, **5AH4EH**

Zero millivolt value——6 bits

For example:

**02 30 31 31 43 5A 4E 30 31 32 36 31 30 38 31 0D 0A**

Correct response:**02 30 31 31 43 5A 4E 4F 4B 33 37 0D 0A**

Wrong response:**02 30 31 31 43 5A 4E 45 34 30 34 0D 0A** (Write data error)

### 6.2.3.6 Gain calibration

#### 1) With weights

Send command:

<b>STX</b>	Scale no.	Channel No.	<b>C</b>	<b>GY</b>	Weight value	<b>CRC</b>	<b>CR</b>	<b>LF</b>
------------	-----------	-------------	----------	-----------	--------------	------------	-----------	-----------

Correct response:

<b>STX</b>	Scale no.	Channel No.	<b>C</b>	<b>GY</b>	<b>O</b>	<b>K</b>	<b>CRC</b>	<b>CR</b>	<b>LF</b>
------------	-----------	-------------	----------	-----------	----------	----------	------------	-----------	-----------

Wrong response:

<b>STX</b>	Scale no.	Channel No.	<b>C</b>	<b>GY</b>	<b>E</b>	Error code	<b>CRC</b>	<b>CR</b>	<b>LF</b>
------------	-----------	-------------	----------	-----------	----------	------------	------------	-----------	-----------

Here:

**GY**—2 bits, **47H 59H**

Weight value—**6 bits**: Write in weight value

For example:

**02 30 31 31****43 47 59 30 30 30 32 30 30 36 35 0D 0A** (Write in: weight value **200**)

Correct response: **02 30 31 31 43 47 59 4F 4B 32 39 0D 0A**

Wrong response: **02 30 31 35 43 47 59** **45 36 30 32 0D 0A** (Channel no. error)

## 2) Without weights

Send command:

STX	Scale no.	Channel No.	C	GN	Gain millivolt	Weight value	CRC	CR	LF
-----	-----------	-------------	---	----	----------------	--------------	-----	----	----

Correct response:

<b>STX</b>	Scale no.	Channel No.	<b>C</b>	<b>GN</b>	<b>O</b>	<b>K</b>	<b>CRC</b>	<b>CR</b>	<b>LF</b>
------------	-----------	-------------	----------	-----------	----------	----------	------------	-----------	-----------

Wrong response:

<b>STX</b>	Scale no.	Channel No.	<b>C</b>	<b>GN</b>	<b>E</b>	Error code	<b>CRC</b>	<b>CR</b>	<b>LF</b>
------------	-----------	-------------	----------	-----------	----------	------------	------------	-----------	-----------

Here:

Gain millivolt—**6 bits**

Weight value—**6bits**

For example:

**02 30 31 31****43 47 4E 30 30 31 39 34 30 30 30 30 32 30 30 35 36 0D 0A** (Write in: weight value **200**, corresponding gain millivolt **0.194**)

Correct response: **02 30 31 31 43 47 4E 4F 4B 31 38 0D 0A**

Wrong response: **02 30 31 31 43 48 4E** **45 33 38 35 0D 0A** (Para. Code error)

### 6.2.3.7 Zeroing

Send command:

<b>STX</b>	Scale no.	Channel No.	<b>O</b>	<b>CZ</b>	<b>CRC</b>	<b>CR</b>	<b>LF</b>
------------	-----------	-------------	----------	-----------	------------	-----------	-----------

Correct response:

<b>STX</b>	Scale no.	Channel No.	<b>O</b>	<b>CZ</b>	<b>O</b>	<b>K</b>	<b>CRC</b>	<b>CR</b>	<b>LF</b>
------------	-----------	-------------	----------	-----------	----------	----------	------------	-----------	-----------

Wrong response:

<b>STX</b>	Scale no.	Channel No.	<b>O</b>	<b>CZ</b>	<b>E</b>	Error code	<b>CRC</b>	<b>CR</b>	<b>LF</b>
------------	-----------	-------------	----------	-----------	----------	------------	------------	-----------	-----------

For example:

**02 30 31 31 4F 43 5A 38 34 0D 0A**

Correct response: **02 30 31 31 4F 43 5A 4F 4B 33 38 0D 0A**

Wrong response: **02 30 31 31 4F 43 5A 45 35 30 36 0D 0A** (Operation can't execute)

### 6.2.3.8 CRC computation

All the values in front of the parity bit add together and convert to decimal data, then convert the last 2 bits to **ASCII** code (decade in front and the unit at the back).

For example

The following is a frame of data:

<b>0</b>	<b>3</b>	<b>3</b>	<b>3</b>	<b>4</b>	<b>4</b>	<b>5</b>	<b>3</b>	<b>3</b>	<b>0</b>	<b>0</b>
----------	----------	----------	----------	----------	----------	----------	----------	----------	----------	----------

**Add 02~5A: 180(Hex), convert to decimal data: 384.** We can calculate from this

that the check code is **38,34** for the data frame.

### 6.3 tt TOLEDO Protocol

When choose “tt” protocol in working parameter F2.3, indicator will send datas in continuous mode with TOLEDO protocol.

Continuous sending mode format as below:

<b>1</b>	<b>2</b>	<b>3</b>	<b>4</b>	<b>5</b>	<b>6</b>	<b>7</b>	<b>8</b>	<b>9</b>	<b>10</b>	<b>11</b>	<b>12</b>	<b>13</b>	<b>14</b>	<b>15</b>	<b>16</b>	<b>17</b>	<b>18</b>	
<b>STX</b>																	<b>0D</b>	

~
**A**   **B**   **C**   display weight(6 bits)   6 个 30H   Checksum

Here:start character is standard **ASCII** start character **02(STX)**

status byte **A** definition as below:

<b>D0</b>	<b>0</b>	<b>1</b>	<b>0</b>	<b>1</b>	<b>0</b>
<b>D1</b>	<b>1</b>	<b>1</b>	<b>0</b>	<b>0</b>	<b>1</b>
<b>D2</b>	<b>0</b>	<b>0</b>	<b>1</b>	<b>1</b>	<b>0</b>
Decimal point	<b>x</b>	<b>.x</b>	<b>.xx</b>	<b>.xxx</b>	<b>.xxxx</b>

**D3**   **D4**   **D6** 为 **0(not change)**   **D5** is **1(not change)**

status byte **B** definition as below:

D6	D5	D4	D3	D2	D1	D0
Status			Stable	Overflow	symbol	G.W.
<b>Is 0</b> (not change)	<b>Is 1</b> (not change)	<b>Is 1</b> (not change)	<b>1</b> -unstable <b>0</b> -stable	<b>1</b> -overflow <b>0</b> -normal	<b>1</b> -negative <b>0</b> -positive	<b>Is 0</b> (not change)

status byte **C** is reserved, output 20H.

## 6.4 Cb920

When **F2.3=Cb920** in working parameter, indicator will send weighing data continuously without command under **Cb920** protocol.

Data format:

Status	,	G.W.	0/1	Symbol	Display	Unit	CR	LF
--------	---	------	-----	--------	---------	------	----	----

Here :

**Status** —— 2 bits, **OL**: ( 4FH 4CH )OFL; **ST**: ( 53H 54H )Stable; **US**: ( 55H 53H )unstable

, — 1 bit, separator 2CH

**G.W.** — 2 bits, **GS: gross weight 47H 53H**

**0/1** — 1 bit, (30H/31H) interleaved transmission

**Symbol** — 1 bit, 2BH (+) , 2DH (-)

**Display** — 7 bits, including decimal point

**Unit** — 2 bits, blank space (20H 20H)

**CR** — 1 bit, 0DH

**LF** — 1 bit, 0AH

For example: When indicator send the following automatically:

**53 54 2C 47 53 31 2B 20 20 31 39 30 2E 31 20 20 0D 0A**

Means: Stable、G.W.、Data value is positive、current weight is **190.1**

## 6.5 rECont

Indicator will send weighing data to the upper computer continuously without any command.

Return data frame format specification :

Status	,	<b>GS</b>	,	+/-	Display	Unit	<b>CR</b>	<b>LF</b>
--------	---	-----------	---	-----	---------	------	-----------	-----------

<b>2bits</b>	<b>2C</b>	<b>47 53</b>	<b>2C</b>	<b>2B/2D</b>	<b>7bits</b>	<b>6B 67</b>	<b>0D</b>	<b>0A</b>
--------------	-----------	--------------	-----------	--------------	--------------	--------------	-----------	-----------

Here:

Status — **2 bits**, **OL(OFL):4FH 4CH; ST(stable):53H 54H; US(unstable):55H 53H**

Display value — **7bits**, including decimal point, high bit is blank if no decimal point.

For example: When indicator send the following automatically:

**53 54 2C 47 53 2C 2B 30 31 31 2E 31 32 30 6B 67 0D 0A**

Means: Stable, Data value is positive, display value is **11.120kg**

## 6.6 rEREAD

Indicator will send weighing data to the upper computer under command.

Data format:

Data	<b>R</b>	<b>E</b>	<b>A</b>	<b>D</b>	<b>CR</b>	<b>LF</b>
explain	<b>52H</b>	<b>45H</b>	<b>41H</b>	<b>44H</b>	<b>0DH</b>	<b>0AH</b>

The return data frame is the same with that of **rECont** protocol, please refer to **rECont**.

- 1) Zero clearing command: ZERO ON<CR><LF> : **5A 45 52 4F 20 4F 4E 0D 0A**

Return YES<CR><LF> or NO? <CR><LF>



2) Calibration zeroing command: TARE ON<CR><LF> : **54 41 52 45 20 4F 4E 0D 0A**

Return YES<CR><LF> or NO? <CR><LF>

3) Read ID no.: GET ID<CR><LF> : **47 45 54 20 49 44 0D 0A**

Return ASCII code with 6 digits ID no.

## 6.7 Modbus

Indicator uses **RTU mode** to communicate, every 8-bit byte of the message are divided into 2pcs of 4-bit hexadecimal characters to transmit at binary code.

**Code: Binary**

**Function code:**

Function code	Definition	Description
<b>03</b>	read the register	
<b>06</b>	preset single register	
<b>16</b>	preset several registers	Command only support preset double registers.
<b>01</b>	read coil	The length unit is bit.
<b>05</b>	<b>write coil</b>	

**Exception code response**

Code	Definition	Description
02	Illegal data address	Data address received from error code is not allowed
03	Illegal data value	Data wrote in is not in permissible range
04	machine fault	When indicator is trying to execute operation required, unrecoverable error is produced.
07	Unsuccessful programming request	Command received can't be executed under current condition.

### 6.7.1 Modbus communication address

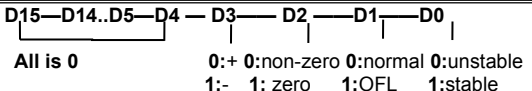
PLC addr.	Display addr.	Description
<b>The following items are only-read register(code 0x03)</b>		
40001	0000	Present weight value(4bits including sign characters, the high bit is in the front)
40002	0001	
40003	0002	 <p style="margin-left: 40px;"> <b>All is 0</b>                      <b>0:+ 0:non-zero 0:normal 0:unstable</b>  <b>1:- 1: zero 1:OFL 1:stable</b> </p>
40004	0003	Reserve(permit to read, reading value is 0 )
.....	.....	
40006	0005	

**The following items are two bytes and are available to read and write  
(write code 0x06, read code 0x03)**

<b>40007</b>	<b>0006</b>	Zeroing(zeroing when write in non-zero value)
<b>40008</b>	<b>0007</b>	Automatically zeroing when power on ( <b>0: OFF; 1: ON</b> )
<b>40009</b>	<b>0008</b>	Zero tracking range ( <b>0-9d</b> )
<b>40010</b>	<b>0009</b>	Stable range ( <b>1-9d</b> )
<b>40011</b>	<b>0010</b>	Zeroing range ( <b>0%-99%</b> )
<b>40012</b>	<b>0011</b>	Digit filter parameters( <b>0-9</b> )
<b>40013</b>	<b>0012</b>	Stability filter series( <b>0-9</b> )
<b>40014</b>	<b>0013</b>	<b>AD sample rate: 0:15/s 1:30/s 2:60/s 3: 120 /s 4:480/s 5:960/s</b>
<b>40015~ 40018</b>	<b>0014~ 0017</b>	<b>Reserved</b>
<b>40019</b>	<b>0018</b>	Decimal point place <b>0:0bit,1:1bit,2:2bits,3:3bits,4:4bits</b> )
<b>40020</b>	<b>0019</b>	Minimum division ( <b>1/ 2/ 5/ 10/ 20/ 50</b> )

**The following items are available to read and write  
(writing code 0x10, read code 0x03)**

<b>40021</b>	<b>0020</b>	Maximum capacity (max.capacity≤mini.division× <b>100000</b> )
<b>40022</b>	<b>0021</b>	

40023	0022	Zero calibration with weights: write in 1 and calibrate zero with the current weight. Read: Absolute millivolt of current load cell
40024	0023	
40025	0024	Zero calibration without weights: Write millivolt value at zero; Write in range (load cell <b>3mV/V</b> :millivolt value range within <b>0.02-12.000mV</b> ) millivolt value at zero when read.
40026	0025	
40027	0026	Gain calibration with weights. Write weight value( $\leq$ max. capacity). Return millivolt at present weight value when read
40028	0027	
40029	0028	Gain calibration without weights ; input gain millivolt(load cell <b>3mV/V:0.000</b> < millivolt< <b>15.000mV</b> – zero millivolt).Read: millivolt value for gain calibration.
40030	0029	
40031	0030	Gain calibration weight without weights. input gain millivolt( $\leq$ max. capacity) Read: weight value for gain calibration.
40032	0031	
40033~40040	0032~0039	<b>reserved</b>
40041	0040	Set point <b>1 stable or not (0: no; 1: yes)</b>
40042	0041	Set point <b>1 min. duration time (0-999 : 0-99.9sec.)</b>
40043	0042	Set point <b>1 valid condition</b>
40044~40045	0043~0044	Set point <b>1 set value 1</b>

<b>40046~40047</b>	<b>0045~0046</b>	Set point 1 set value2
<b>40048</b>	<b>0047</b>	Set point 2 <b>stable or not (0: no; 1: yes)</b>
<b>40049</b>	<b>0048</b>	Set point 2 min. duration time ( <b>0-999 : 0-99.9sec.</b> )
<b>40050</b>	<b>0049</b>	Set point 2 <b>valid condition</b>
<b>40051~40052</b>	<b>0050~0051</b>	Set point 2 set value1
<b>40053~40054</b>	<b>0052~0053</b>	Set point 2 set value2
<b>40055</b>	<b>0054</b>	Set point 3 <b>stable or not (0: no; 1: yes)</b>
<b>40056</b>	<b>0055</b>	Set point 3 min. duration time ( <b>0-999 : 0-99.9sec.</b> )
<b>40057</b>	<b>0056</b>	Set point 3 <b>valid condition</b>
<b>40058~40059</b>	<b>0057~0058</b>	Set point 3 set value 1
<b>40060~40061</b>	<b>0059~0060</b>	Set point 3 set value 2
<b>40062</b>	<b>0061</b>	Set point 4 <b>stable or not (0: no; 1: yes)</b>
<b>40063</b>	<b>0062</b>	Set point 4 min. duration time ( <b>0-999 : 0-99.9sec.</b> )
<b>40064</b>	<b>0063</b>	Set point 4 <b>valid condition</b>
<b>40065~40066</b>	<b>0064~0065</b>	Set point 4 set value 1
<b>40067~40068</b>	<b>0066~0067</b>	Set point 4 set value 2
<b>40069</b>	<b>0068</b>	Output 1 user-defined
<b>40070</b>	<b>0069</b>	Output 2 user-defined
<b>40071</b>	<b>0070</b>	Input 1 user-defined

<b>40072</b>	<b>0071</b>	I/O output value	Note: available only when coil address 00016 is valid. Input write 1 valid, 0 invalid. Read 1 valid, 0 invalid
<b>40073</b>	<b>0072</b>	I/O input value	
<b>Reserved</b>			
<b>40401</b>	<b>0400</b>	<b>Current weight value( 4 bytes with symbolic number, high digit in front)</b>	
<b>40402</b>	<b>0401</b>		
<b>40403</b>	<b>0402</b>	<b>D15—D14……D4 0</b> <b>D3 0:+ 1:-</b> <b>D2 0:non-zero 1:zero</b> <b>D1 0:normal 1:OFL</b> <b>D0 0:Stable 1:Unstable</b>	
<b>40404</b>	<b>0403</b>	<b>0</b>	
<b>40405</b>	<b>0404</b>	<b>6 digits without symbolic number, user ID no.</b>	
<b>40406</b>	<b>0405</b>		
<b>The following items are bit read only. (read code: 0x03)</b>			
<b>49001</b>	<b>9000</b>	Version no.	If display10024, formatXX XXXX,main version no., hardware no., software no..So main version no.01 , hardware no. 00, software no. 24
<b>49002</b>	<b>9001</b>		

<b>49003</b>	<b>9002</b>	<b>Develop time</b>	If display 141024, means 24 <sup>th</sup> Oct., 2014
<b>49004</b>	<b>9003</b>		
<b>The following items are bit read only. (read code: 0 x 0 1)</b>			
<b>00001</b>	<b>0000</b>	<b>0: unstable; 1: stable</b>	
<b>00002</b>	<b>0001</b>	<b>0: normal; 1: OFL</b>	
<b>00003</b>	<b>0002</b>	<b>0: non-zero; 1: zero</b>	
<b>00004</b>	<b>0003</b>	<b>0: +; 1: -</b>	
<b>00005</b>	<b>0004</b>	<b>Reserved</b>	
<b>00006</b>	<b>0005</b>	<b>Reserved</b>	
<b>The following item are available to read and write (read code: 0x01, writing code: 0x05)</b>			
<b>00007</b>	<b>0006</b>	<b>Automatically zeroing when power on (0: OFF; 1: ON)</b>	
<b>00008</b>	<b>0007</b>	<b>Reserved</b>	
<b>00009</b>	<b>0008</b>	<b>Reserved</b>	
<b>00010</b>	<b>0009</b>	Reset all	
<b>00011</b>	<b>0010</b>	Reset calibration	
<b>00012</b>	<b>0011</b>	Reset paramaters	
<b>00013</b>	<b>0012</b>	Reset I/O	

<b>00014</b>	<b>0013</b>	<b>Reserved</b>	
<b>00015</b>	<b>0014</b>	<b>Reserved</b>	
<b>00016</b>	<b>0015</b>	I/O testing switch	
<b>00017</b>	<b>0016</b>	Set point 1 status	Only read: 0:invalid, 1:valid
<b>00018</b>	<b>0017</b>	Set point 2 status	
<b>00019</b>	<b>0018</b>	Set point 3 status	
<b>00020</b>	<b>0019</b>	Set point 4 status	
<b>00021~ 00032</b>	<b>0020~ 0031</b>	<b>Reserved</b>	



## 7 Password Input and Setting, Reset

### 7.1 Password Input

- (1) Indicator calibration and working paraters setting default password: **000000**.
- (2) User can set password in parameters when **F4.1** is“**ON**”.
- (3) When display is “PASS”, need to input correct password to enter parameters.

Note:

- (1) When input password, if first time wrong, it will go to the second chance for password input(display from **0 - - - -** turn to **0 = = = =**).
- (2) If second input wrong, it will enter into interface for inputting password the third time  
(Display change from **0 = = = =** to **0 = = = =**).
- (3) If Input wrong for three times, main display show “Error4” and self-lock, but user can operate when power on again.

### 7.2 Password Setting

- (1) User can set password in parameters when **F4.1** is“**ON**”.

- (2) User must input same new password twice in setting password, If not same, main display show "**Error**" one second and return to **PASS** again.

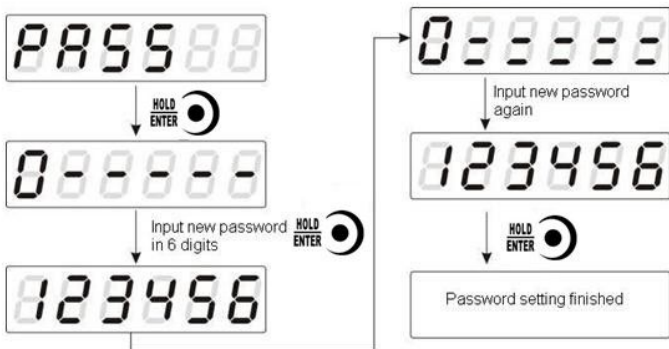

## 7.3 Factory Reset

**Note:** Factory reset is only for special technicians, which will reset all of parameters and will maybe cause not working.

Take reset all for example:

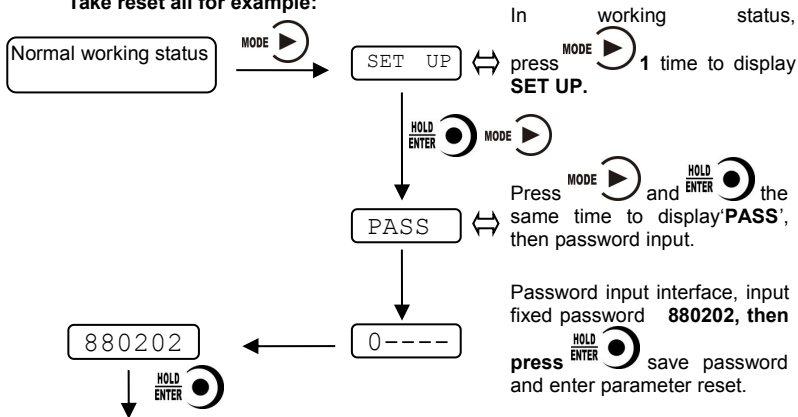

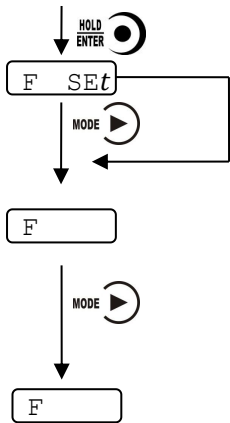

⇔ 1) In **F Set** interface, press **HOLD ENTER** to reset working parameters, enter into reset calibration parameters interface.

2) In **F Set** interface, press **MODE**, not to make working parameter reset, enter into calibration parameter reset interface.

⇔ 1) In **F CAL** interface, press **HOLD ENTER** to reset calibration parameter, enter into reset all interface.

2) In **F CAL** interface, press **MODE**, not to make calibration parameter reset, enter into reset all interface.

⇔ 1) In **F ALL** interface, press **HOLD ENTER** to make reset all of the parameters (including working parameter, calibration parameter, I/O etc..)

**Note:** In all reset interfaces, press **ZERO ESC** to exit and return to weighing interface.

## 8 Display Testing

The following flow chart is to test lights on main-display and status lights.

Normal weighing status

SEt UP



Press 5 times MODE



tESt



Under parameter interface, press MODE to switch to "tESt" interface.

HOLD ENTER



8 . 8 . 8 . 8



Under "tESt" interface, press HOLD ENTER to make display testing, Nixie tube display and indicator lights all shine. Now if press HOLD ENTER, display will sparkle.

ZERO ESC



tESt



After testing is finished, press ZERO ESC to return to "tESt" interface.

## 9 Errors and Alarm Messages

**Error** ① Input error.

② wrong data beyond parameter range.

**Error** 2 The present weight value is out of zeroing range.

**Error** 3 Scale platform is not stable when zeroing.

**Error** 4 Input wrong password more than 3 times.

**OFL** Weighing value is positive overflow.

**-OFL** Weighing value is negative overflow.

## 10 Dimension of Indicator

Dimension of rear panel: **92×45(mm)**

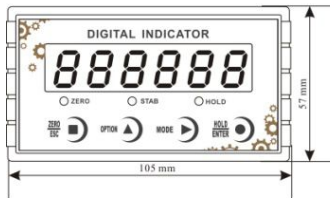
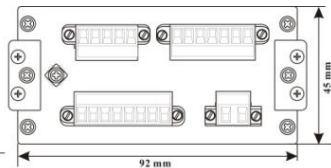

Dimension of front panel: **105×57(mm)**



Panel cutout dimension: **93×46(mm)**

