

VERTICAL CHECKWEIGHER CW-60K-V

CW-60K-V checkweigher has wide weighing range but high accuracy guarantee. It is perfect for weighing the various bags and boxes running in vertical way in the production line.

- Standard module design for easy installation and maintenance;
- Easy integrating in the production line;
- Maximum capacity: **60kg**, weighing accuracy is within **±20g**;

Multiple applications



Standard



Economy Type

Specification

Model	CW-60K-V Standard	CW-60K-V Economy Type
Maximum capacity	60kg	60kg
Best accuracy*	±10g	±20g
Highest speed*	≤50pcs/min	≤30pcs/min
Belt speed	40m/min	22m/min
Conveyor size	800mm*400mm	800mm*400mm
Distance between rollers	800mm	800mm
Weighing platform height	400 (±50mm)	400 (±50mm)
Structure material	Carbon Steel, SS304 (weighingPlatform)	Carbon Steel, SS304 (WeighingPlatform)
Belt material	PVC (black)	PVC (black)
Display	10-inch touch screen	7-inch touch screen
Power	AC220V±10%, 50/60Hz, 825W	AC220V±10%, 50/60Hz, 425W
Working temperature	0~40°C	0~40°C
Max. humidity	90% R.H, non-condensation	90% R.H, non-condensation
Load limit	The instantaneous load limit is 100kg	The instantaneous load limit is100kg

*It depends on the features of tested object, such as size and weight.

Dimensions

Unit:mm

Standard

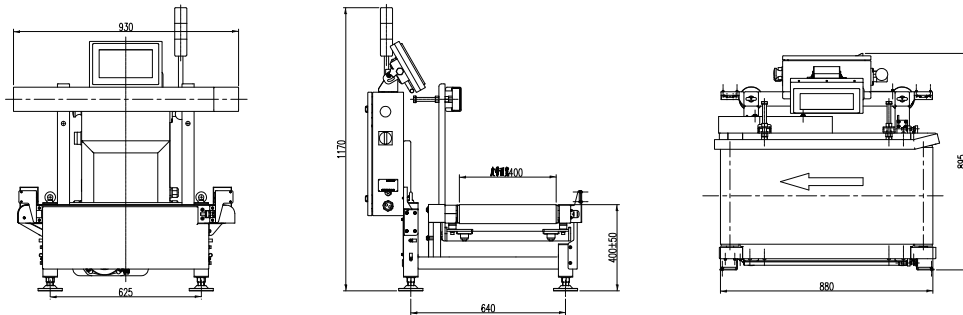

Economy Type

