

# Hawk Pharma Series

## Pharmaceutical Checkweigher

Designed to meet Good Manufacturing Practice (**GMP**) requirements.



# Hawk Pharma Series

Checkweigher designed for pharmaceutical **GMP**



High Speed, Great Efficient  
**400** pcs/min

Wide Weighing Range  
**5~600**g

Display Accuracy  
**±10** mg

Best Accuracy  
**±0.1**g



Hawk Pharma series checkweigher is engineered to comply with pharmaceutical GMP standards, ensuring high-precision, high-speed, and **24/7** stable dynamic weighing performance.

### AI Filtering Technology

Designed for unstable products (e.g., wobbling vials, ampoules, blister packs), **AI algorithms monitor machine vibration and continuously adapt through model-based learning** to ensure accuracy even under complex conditions.

### Non-contact taut belt high accuracy performance weighing platform

Using patented non-contact taut band high-accuracy technology combined with a low-friction aluminum conveyor and precision-controlled servo motor, the system ensures exceptional accuracy on high-speed production lines.

### High-Performance Weighing

Weighing range: **5~600g**; Up to **400** ppm depending on packaging size; Suitable for small-dose or medium-size pharmaceutical packages.



FDA Approval



3Q Documentary



Factory Acceptance Test

### Compliance with Pharmaceutical Regulatory Requirements

- Supports accurate and repeatable dynamic weight measurement. Provides required certifications and supports **FDA 21 CFR Part 11** audit trail.
- Offers fail-safe rejectors, reject verification, open-flap detection, and more.



# Stable and Precise Performance

## Flexible and Convenient

- Compact design with adjustable height, easy to integrate with cartoners;
- Modular weighing unit for easy installation and maintenance;
- Touchscreen with 30° tilt for ergonomic operation;



30° vertical flip



## Durable and Reliable

- Industrial-grade materials and maintenance-free key components reduce the downtime for equipment maintenance. Designed for 24/7 continuous operation.



## Hygienic Design

- GMP-compliant structure with smooth surfaces for easy cleaning meet the requirements of clean production environments to avoid the risk of cross-contamination.



## Air draft cover

- Prevents air turbulence and vibration interference;
- Blocks dust contamination, avoid cross-contamination;
- Transparent for real-time production monitoring.

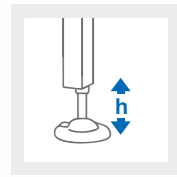

Height adjustable



# Smart and User-Friendly Operation

## User-Friendly Interface

- 15.6-inch full-color touchscreen, editable, intuitive UI;
- One-touch style switching and real-time statistics;



## Intelligent Learning



- AI-based intelligent dynamic filtering; automatic optimization;

## Data Analytics

- Multiple big-data analysis dashboards; Real-time production trend monitoring with SPC;

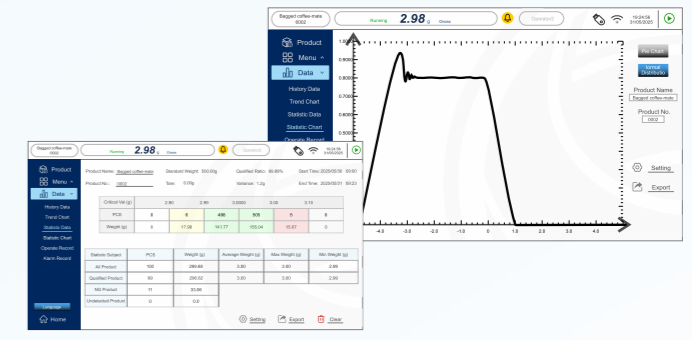

- Up to 200 product recipes improve the efficiency of production turnover;
- 400 GB data storage for full traceability;

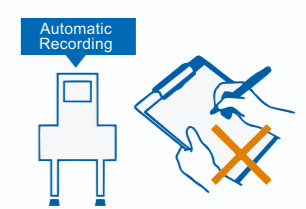

# Application Flexibility

— for pharmaceutical packaging of various forms

Hawk Pharma can weigh diverse pharmaceutical packaging, and through precise weight analysis to achieve the quality control.

**Packaging type** • cartons, glass/plastic bottles, sachets, film packs;

- ✔ Detects missing inserts (e.g., mandatory drug leaflets);
- ✔ Detects missing tablets/capsules or insufficient filling;



## Technical Specifications

| Model                 | Hawk Pharma                |
|-----------------------|----------------------------|
| Weight Range          | 5~600g (0.011~1.32lb)      |
| Top Speed             | 400 ppm                    |
| Best Accuracy         | ±0.1g                      |
| Motor                 | Servo Motor                |
| Structure             | SS304 / Aluminum           |
| Operating Temperature | 0°C~+45°C (+32°F~+113°F)   |
| Humidity              | 20%~90%, Non- condensing   |
| Power Supply          | 200-240VAC, 50/60 HZ, 480W |
| Air Supply            | 5.5-6.9 bar (80-100 psi)   |
| IP Grade              | <b>IP54</b>                |
| Line Height           | 800mm±50mm                 |
| Communication         | RS485, Modbus TCP/IP       |

1. The actual accuracy depends on the product's length, weight, speed and stability.
2. The push rejector needs an independent conveying device, and the cantilever length of the conveyor should not exceed 1250mm (combined configuration).

## Dimensions (Unit: mm)

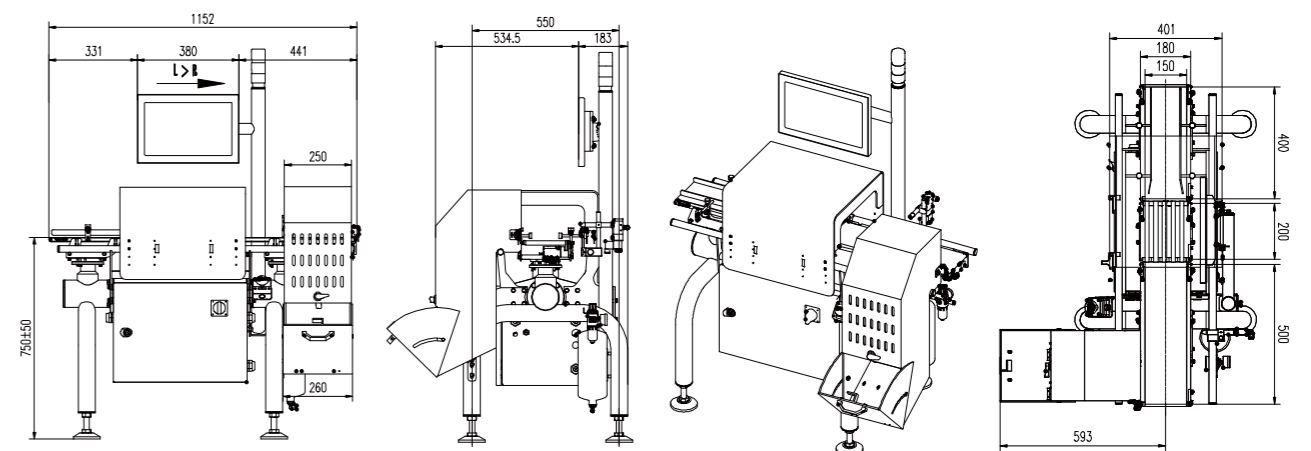

\*Parameters and dimensions may be upgraded. Please consult in real time for the latest information.

