



杰 · 曼 · 科 · 技

# GMC-P7-F8

## Batching

# User Manual

110612070006

V05.00.01

Zhuzhou General Measure Technology Co., LTD. All rights reserved.  
Without the permission of Zhuzhou General Measure Technology Co., LTD., no unit or individual may copy, transmit, transcribe or translate into other language versions in any form or by any means.



**Warnings**

The product is powered by **DC24V** power supply, misuse of AC220V power supply will permanently damage the instrument.

Keep the instrument well grounded.

The product is an electrostatic sensitive device. Take ESD measures during use and maintenance

**Standards &  
Certifications**

Product standard: **GB/T 7724-2023**

## Catalogue

Chapter 1 Overview .....	- 1 -
1.1 Functions and features.....	- 1 -
1.2 Technical Specifications .....	- 1 -
1.2.1 General Specifications.....	- 1 -
1.2.2 Analog part .....	- 1 -
1.2.3 Digital part.....	- 2 -
1.3 Front Panel description.....	- 2 -
1.4 Description of the rear panel .....	- 3 -
Chapter 2 Installation and wiring .....	- 4 -
2.1 General Principles .....	- 4 -
2.2 Loadcell Connection .....	- 4 -
2.3 IO interface connection .....	- 5 -
2.4 Power Wiring.....	- 6 -
2.5 Serial Port Connection.....	- 6 -
2.6 Network Port Connection.....	- 7 -
2.6.1 Troubleshooting Network Port Faults .....	- 7 -
2.7 User Permission description.....	- 7 -
Chapter 3 Menu overview .....	- 9 -
3.1 Menu .....	- 9 -
3.2 Basic Parameters .....	- 10 -
3.2.1 Basic Parameters .....	- 10 -
3.3 Calibration.....	- 11 -
3.3.1 Calibration parameters .....	- 11 -
3.3.2 Zero calibration .....	- 12 -
3.3.3 Weight calibration .....	- 13 -
3.3.4 Theroy Calibration .....	- 13 -
3.4 IO module.....	- 14 -
3.4.1 Input .....	- 14 -
3.4.2 Output.....	- 14 -
3.4.3 I/O test.....	- 15 -
3.5 Recipe Setting .....	- 15 -
3.5.1 Recipe Interface Description .....	- 16 -
3.5.2 Description of Batching process.....	- 16 -
3.6 Communication Settings .....	- 17 -
3.6.1 Serial Port Parameters .....	- 17 -
3.6.2 Network Port Parameters.....	- 17 -
3.6.3 Peripherals Parameters .....	- 17 -
3.7 History Record .....	- 19 -
3.8 Maintenance .....	- 19 -
3.8.1 Parameter Description .....	- 20 -
3.8.2 Display Style Description.....	- 21 -
3.8.3 COM Test .....	- 22 -
3.8.4 USB Drive Upgrade software.....	- 22 -
3.9 Working parameters.....	- 23 -
3.10 Communication protocol and address .....	- 23 -
3.10.1 Modbus Protocol .....	- 23 -
3.10.2 Cont-A (continuous send -CB920).....	- 36 -
3.10.3 Cont-B (Continuous transmission -tt) .....	- 37 -
3.10.4 r-Cont.....	- 37 -
3.10.5 rE-Cont .....	- 38 -
3.10.6 YH .....	- 38 -
Chapter 4 Product Size.....	- 39 -
4.1 Tray Size.....	- 39 -
4.2 Desktop installation dimensions.....	- 40 -

# Chapter 1 Overview

## 1.1 Functions and features

- All english touch screen display interface, make the operation more intuitive and simple
- It can store 10 groups of recipes, and each group can be used for the blending of 20 kinds of materials.
- **14** input and output control (**5 in/9 out**), input and output port functions can be customized.
- IO test function, convenient debugging
- Time/Date function
- Three-level user permission Settings
- Three serial ports for external serial printers, computers, or second monitors
- Support a variety of communication Modbus, command mode, continuous send mode, printing mode
- Different printer types can be selected by printing method.
- The USB interface is convenient for exporting historical data.

## 1.2 Technical Specifications

### 1.2.1 General Specifications

Power Supply: **DC24V**

Power filter: included

Operating temperature: **-10 ~ 40°C**

Max humidity: **90% R.H.** No condensation

Power consumption: about **15W**

Physical dimensions: **233mm \* 168mm \* 63mm**

Product weight: **1542g**

### 1.2.2 Analog part

Loadcell power supply: **DC5V 125mA (MAX)**

Input impedance: **10MΩ**

Zero adjustment range: **0.002 ~ 15mV (when the loadcell is 3mV/V)**

Input sensitivity: **0.02uV/d**

Input range:**0.02~15mV**

Conversion mode: Sigma-Delta

A/D conversion speed: **50~960** times/second, 10 kinds of sampling speed optional

Non-linear: **0.01% F.S**

Increment drift: **10PPM/ °C**

### 1.2.3 Digital part

Display: 7 "inch touch screen

Negative display: "-"

Overload display: "Weight Out of Capacity/loadcell overflow negatively "

Decimal point: 5 optional

### 1.3 Front Panel description



① User display area: Display the currently logged-in user and system time. Clicking on the current user will return to the not log in status.

② Weight status area: It includes weight display, weighing unit display, status mark display, as well as display of current gross weight value, net weight value and tare weight value.

③ Recipe information area: View the current recipe, cumulative total weight and current material status information.

④ Function key area: Quick keys such as menu, tare, view history, zero, and enter recipe parameters.

## 1.4 Description of the rear panel

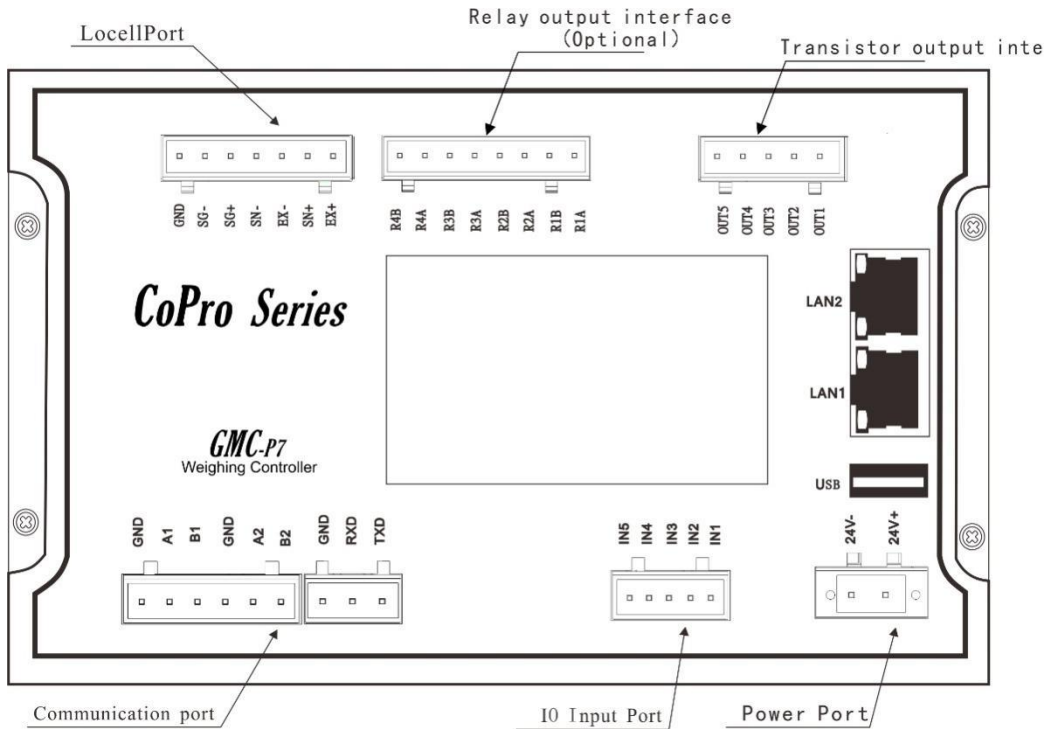

## Chapter 2 Installation and wiring

### 2.1 General Principles

The GMC-P7 controller has two installation forms: desktop and panel-mounted

Panel-mounted installation form

- 1) Make holes in the appropriate position of the control cabinet (hole size **214 (±1) mm × 148(±1) mm**)
- 2) Load the instrument into the control cabinet.
- 3) Take out the side strip from the fitting that comes with the instrument, fix it on both sides of the instrument, and secure it with **M4\*12** screws.

Desktop: The size of the bracket opening is shown in the right figure

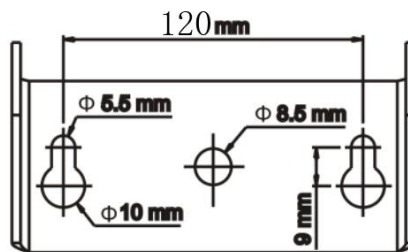

### 2.2 Loadcell Connection

The GMC-P7(F8) weighing controller needs to be connected to an external resistance strain bridge weighing loadcell, and each port of the connection terminal is allocated to:

Ports	EX+	SN+	EX-	SN-	SIG+	SIG-	SHL
Six-wire system	Power positive	Sensitive positive	Power negative	Sensitive negative	Signal Positive	Signal Negative	Shielded wire

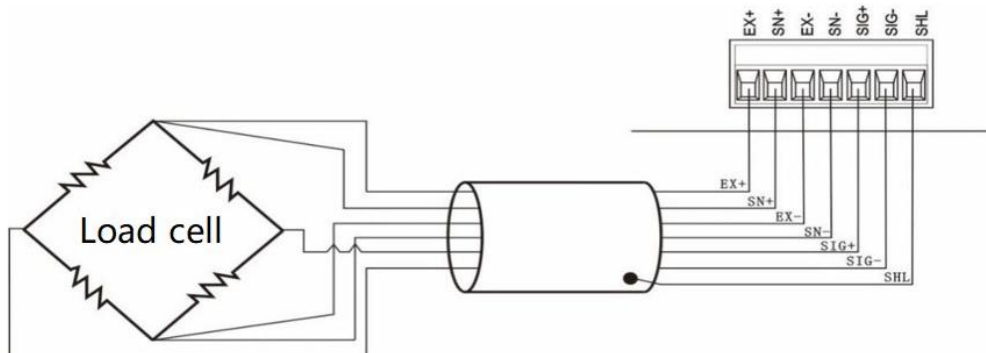

#### Notes:

1. Because the loadcell output signal is an analog signal that is more sensitive to electronic noise, the loadcell wiring should be shielded cables, and be laid separately from other cables, especially away from AC power;

2. Four-wire loadcell can be selected for occasions where the transmission distance is short and the temperature change is not large or the accuracy requirements are not high; However, for applications with long transmission distance or high accuracy requirements, six-wire loadcell should be selected;

3. For the application of multiple loadcells in parallel, it is necessary to ensure that the sensitivity of each loadcell ( $mV/V$ ) is consistent

### 2.3 IO interface connection

**GMC-P7(F8)** weighing controller includes **14** input and output control interface functions (**5** in and **9** out), which adopts photoelectric isolation mode and driven by internal power supply. **5** input port **9** output (output port **1~5** transistor collector open output mode, can switch high and low levels, each drive current is **200mA**, Output **6~9** is the relay output). The factory default low level of the input and output interfaces is valid. Each input and output has no function by default, and the user can set the IO parameters.

Instrument input interface schematic diagram:

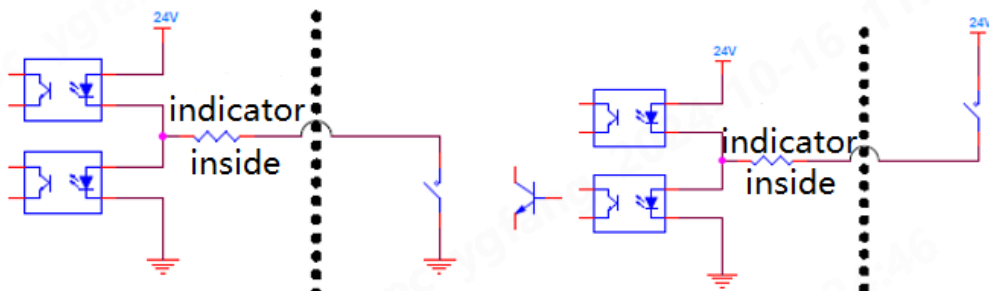

Low level mode

High level mode

Instrument output interface schematic diagram:

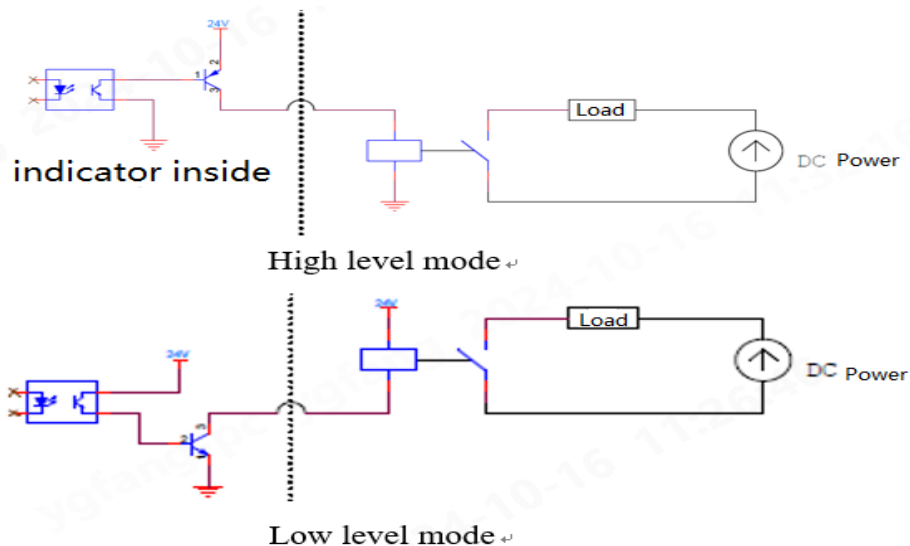

High level mode

Low level mode

## 2.4 Power Wiring

**GMC-P7(F8)** Weighing controller enables **24V** power supply.

The wiring of the power terminal is shown below:

Note: This product uses 24V DC power supply,

Using 220V AC power will permanently damage the instrument.

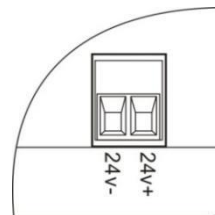

## 2.5 Serial Port Connection

**GMC-P7(F8)** provides two serial **RS485** communication interfaces, one **RS232** communication interface, the interface is shown in the following figure. Serial port 1 is RS-485 mode (serial port: **A1, B1, GND1**); Serial port 2 is RS-485 (serial port: **A2, B2, GND2**) and serial port 3 is RS-232 (serial port: **TX, RX, GND**). Serial port support: **MODBUS** protocol, **continuous send** mode, **YH** protocol and **print** mode. **COM1, COM2**: Standard instrument serial port **RS485**.

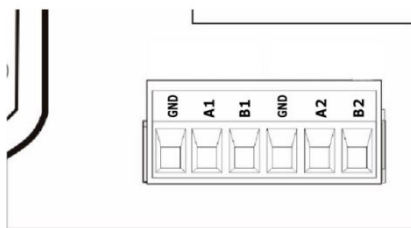

Instrument and computer connection diagram

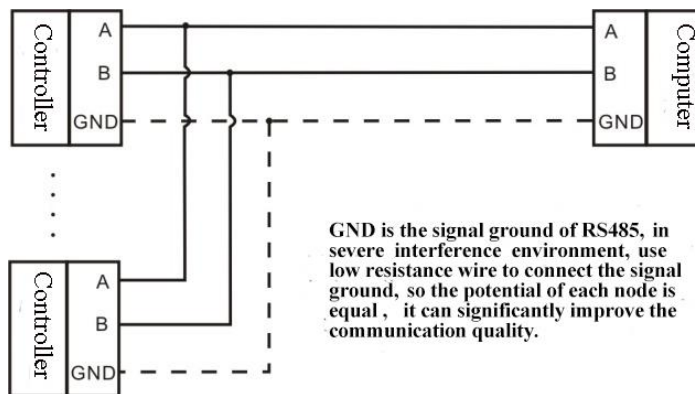

Instrument and host computer connection diagram (**RS-485** mode)

**COM3**: Instrument standard serial port **RS232**

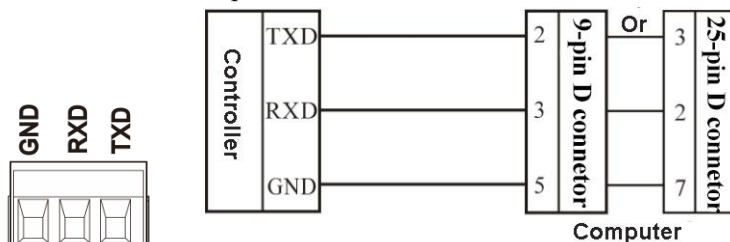

Instrument and host computer connection diagram (**RS-232** mode)

Note: If the serial port cannot communicate, please check:

- a) The **RS485** interface must be connected to **A** and **B** wires.
- b) **GND** must be connected in **RS232** mode.
- c) Make sure that the parameters of the connection port are consistent with those of the upper computer. The slave number, baud rate, data format and communication protocol must be consistent with the upper computer and PLC.

## 2.6 Network Port Connection

GMC-P7(F8) products support ordinary network port communication (optional function, order need to declare). Support TCP protocol (**Modbus/TCP, Cont-A/TCP, Cont-B/TCP, r-Cont/TCP, rE-Cont/TCP, YH/TCP**).

Dual network port option, network port built-in switch, easy to cascade.

With the single-network port option, TCP is supported.



### 2.6.1 Troubleshooting Network Port Faults

**If the network port is not communicating, please check:**

- 1) Check the network port indicator.  
The hardware connection is normal, and the internal communication light of the instrument indicator is always on. The network cable is connected properly, and the connection indicator is blinking.
- 2) Check whether the communication protocol is consistent with the host computer and PLC.
- 3) Verify that GMC-P7 (F8) can be pinged by the network. If not, check the hardware interface section.
- 4) Confirm whether there is an **IP** conflict.
- 5) Restart the instrument.

## 2.7 User Permission description

In order to prevent personnel from misoperating the instrument, the **GMC-P7 (F8)** transmitter provides level 3 permissions (operator, administrator) to select, operator and administrator permissions are as follows:

Permissions	Operation content
Not Log in	Only historical records can be viewed and exported via a USB flash drive. Other interfaces cannot be viewed, and the buttons on the main interface are unavailable.
Operator	The recipe interface can be viewed and the recipe number can be modified. The calibration interface and system maintenance interface cannot be viewed. Settings can be made on all other interfaces.
Technician	Can perform all the privileges of operator.

	The parameters of the recipe parameter interface can be set, calibration can be performed, and system maintenance parameters can be viewed and set, including reset parameters, system language setting, user password modification and other parameters.
--	---

Permission description:

- ◆ When the instrument is powered on, it automatically enters the main interface. The default permission is: Not logged in.
- ◆ You can click on "Not Logged In" at the top of the main interface and log in with the corresponding user identity. Click on [Operator], and enter the 3-digit password of the operator in the user password box on the right: 000(unmodifiable); Click on [Technician], enter the 4-digit technician password in the user password box. The technician password can be modified in [Maintenance] - [System Info.] at the change user password section.
- ◆ To switch permissions, click on user permissions at the top of the operation interface, and a "Log Out?" will pop up. The prompt dialog box appears. Then click [Enter] to return to the login interface, and select the corresponding permission and user password for login.

## Chapter 3 Menu overview

### 3.1 Menu

Click the menu to query and modify each parameter item.

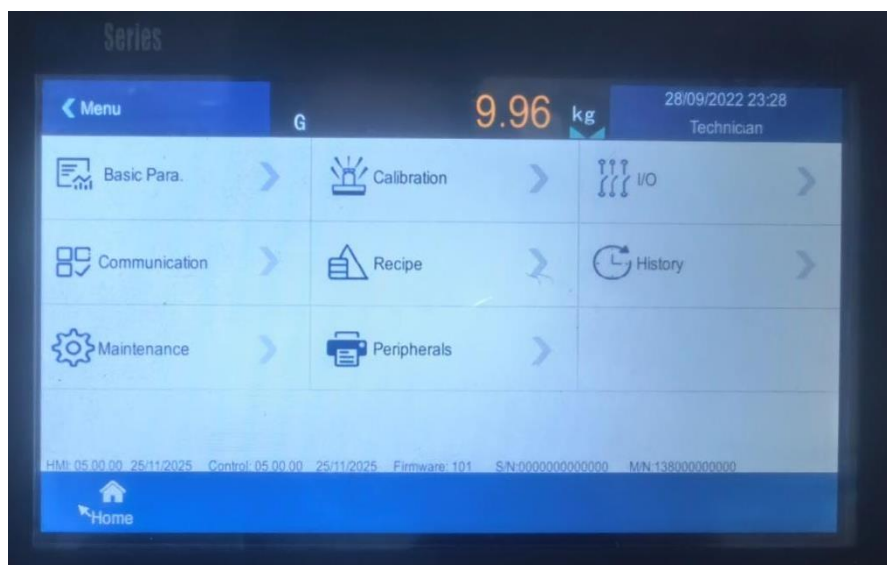

- ◆ Click each parameter to enter the current parameter to view and set the owning parameter information.
- ◆ Click the upper left of the screen to return to the previous screen.

Menu Items	Parameter list	Parameter Description
Basic Parameters	Zero CFG	Set the parameters related to zero.
	STAB&TrZero	Set parameters such as stability judgement and zero trace range time.
	FIR&Sample	Set parameters such as filtering and AD sampling speed
Calibration	Weight CAL	Set the unit, decimal point and perform zero calibration, weight calibration.
	Theory CAL	Calibrate the theoretical values
IO module	Input	Set the input port function, high and low level mode, and debounce time.
	Output	Set output port function, high and low level.
	I/O test	Test whether the input and output ports are connected normally.
Recipe		Set the recipe number, ingredient name, material number, material target value and the corresponding upper and lower limit values.
Communication	COM1	Set the serial port and network port communication format.
	COM 2	

	COM 3	
	Ethernet	
Peripherals	Print	Set parameters such as print format, print language, etc.
Maintenance	Display Style	Set the display style, system time and backlight Settings, and switch the system language.
	COM Test	Use send and receive tests to test whether the communication serial port connection is normal.
	System Information	Display system information as well as change user password and enable remote calibration.
	Reset parameters	Restore parameters to the factory Settings.
	Upgrade	Instrument program upgrade

## 3.2 Basic Parameters

### 3.2.1 Basic Parameters

Parameter Items	Parameter sub item	Instructions
Zero CFG		Successful conditions for zeroing: 1) the weighing platform is stable; 2) the weight is within the zero range. To achieve zero operation: 1) the main interface performed zero operation by press zero key; 2) the input port zero signal is valid; 3) zero by the communication port
	PWR-On Zero	Initial value: <b>0</b> ; Range: <b>0-99</b> (* Full scale %); When this parameter is set to <b>0</b> , disable the automatic power-on zero function. Otherwise, perform zero operation according to the zero range during initial power-on.
	Remote Zero	Initial value: On; If enabled, zero operation can be performed through the communication port. If this parameter is set to off, zero by communication cannot be performed.
	Zero Range	Initial value: <b>20%</b> ; Range: 1 to 99(* Full Scale %)
STAB& TrZero	STAB Range	Initial value: <b>1d</b> ; Range: <b>0-99</b> , when the parameter is <b>0</b> , the stability function is turned off, and the weight stability marker is always valid. When the parameter is not <b>0</b> , during the stability judgment time, if the weight change range has not been greater than the set sub-reading, the weight is stable
	TrZero Range	Initial value: <b>1d</b> ; Range 0-99d. Zero tracking is turned off when the parameter is 0. When the parameter is not zero and the weight change is less than the zero range during the zero track time, the system will automatically track the zero position.
	STAB time	Initial value: <b>1000ms</b> ; Range: <b>1-5000</b> ms. If the weight change range does not exceed the stability range during

		this time, the weight is stable
	TrZero Time	Initial value: <b>1000ms</b> ; Range <b>1-5000ms</b> , in the zero tracking time, the weight change is less than the zero tracking range, then the system will automatically track the zero position
<b>FIR &amp; Sample</b>	Digit-Filter	Initial value: <b>8</b> ; Range: <b>0-9</b> ; The larger the number, the higher the filtering intensity, but the instrument response time will be longer.
	ADV Filter	Initial value: <b>0</b> ; Range <b>0-99d</b> , when <b>0</b> , turn off the steady-state filter. When the parameter is <b>non-0</b> , turn on the steady-state filter if the weight changes within the range
	Sample Rate	Initial value: <b>120</b> ; Range: <b>50; 60; 100; 120; 200; 240; 400; 480; 800; 960 (HZ)</b> .
	Input Range	Initial value: <b>0-10mV</b> ; Range: <b>0-5mV; 0-10mV; 0-15mV</b> Instrument adjusts the signal acquisition range according to the input range to ensure more accurate measuring.

### 3.3 Calibration

When the GMC-P7 (F8) weighing controller or any part of the weighing system is changed for the first time and the current device calibration parameters cannot meet the user's requirements, the instrument should be calibrated. Calibration can determine the system's zero position, gain and so on of the weighing system.

※ **Note: Need to log in as a technician to view the calibration parameters.**

#### 3.3.1 Calibration parameters

Parameters	Parameter sub item	Instructions
Weight CAL	Unit	Initial value: <b>kg</b> ; Range: <b>t; kg; g; lb</b>
	Decimal point	Initial value: <b>0</b> ; Range: <b>0; 0.0; 0.00; 0.000; 0.0000</b>
	Division	Initial value: <b>d=1</b> ; The instrument indicates the minimum change in value Range: <b>1,2,5,10,20,50,100,200,500</b>
	Full Scale	Initial value: <b>10000</b> ; The maximum value of the instrument, generally take the loadcell range. Range: minimum division *200000 can be set. When out of range (" data out of range ") prompt information, so as not to damage the loadcell by weighing overpressure.
	Correction Factor	Initial value: <b>1.00000</b> ; After calibration, if the zero point is correct, there is a deviation in weight, which can be used to correct the weight value. The calculation method of the value: if the instrument shows the weight is <b>A</b> , but the

		weight is <b>B</b> after weighing, the calculation method of the correction factor is :(actual weight <b>B</b> is the current correction factor)/ the displayed weight <b>A</b>
	M-CAL Zero mV	Range: <b>0 to 5.0000mV</b> Manually enter the voltage with <b>4</b> decimal points as the zero point voltage
Auto CAL Zero	After emptying the weighing platform, press this key to take the current acquired voltage value status as the zero voltage.	
CAL Weight	CP1-Voltage	The millivolt value corresponding to the calibration weight. When the previous points are calibrated, the relative millivolts of the other points will be reset to the uncalibrated state (default: <b>10.0000mV, 10000kg</b> ). For example, after calibration point 1, calibration points 2-5 are reset to 0
	CP2-Voltage	
	CP3-Voltage	
	CP4-Voltage	
	CP5-Voltage	
	CP1-Weight	the weight calibration point and enter the weight value of the corresponding weight. Range: <b>0</b> to maximum range. Refer to <a href="#">section 3.3.3 Weight calibration instructions</a> for details.
	CP2-Weight	
	CP3-Weight	
	CP4-Weight	
	CP5-Weight	
Theory CAL	Loadcell mV/V	Initial value: 2.0000; Range: 0.000-3.9999. Loadcell true sensitivity, 4 decimal points, if multiple Loadcells is the average sensitivity
	VC Capacity	Initial value: <b>10000</b> ; Range: <b>0</b> ~ maximum range. Loadcell true range, if there are multiple loadcells, is the sum of all loadcell ranges
	Use T-CAL	Initial value: Off; Range: Off; On. Enable theoretical value calibration for theoretical value calibration to take effect.

### 3.3.2 Zero calibration

Zero calibration means zero calibration of the weighing platform.

There are two ways to perform zero calibration: automatic zero and manual zero millivolts. When the new equipment or weighing structure is adjusted, the "Auto CAL Zero" method must be used for zero calibration.

#### Auto CAL Zero

Calibration success condition: the weighing platform is stable.

Calibration interface displays the loadcell voltage value. After emptying the weighing platform, press [Auto CAL Zero] key, the relative zero voltage value is **0.0000mV**, that is, the current state is calibrated to the zero state. As shown in the following picture:

Loadcell Voltage	0.6688mV
Relative Gain Voltage	0.6688mV

#### M-CAL Zero V

In the manual zero millivolt in the [CAL Weight] interface, manually enter the zero corresponding millivolt value, that is, the input value status is calibrated to zero.

※ Generally used in the case of no weight calibration, the value recorded by the data recorded during the weight calibration is used for manual input.

### 3.3.3 Weight calibration

Weight calibration means weight calibration with standard weights.

The instrument supports **5-point** calibration, which provides users with the maximum number of calibration points according to their requirements.

#### Calibration method:

※ The zero point calibration should be completed before the weight calibration.

Step: Press the key of "Weight calibration", load the weight to the weighing platform, and enter the weight value corresponding to the weight in the calibration point X weight. (X=1~5)

Note the use of multi-point calibration:

- 1) The user can choose the number of calibration points, such as single point calibration, after the completion of the calibration of the first weight point that is, the weight of the calibration point 1 weight can be quit.
- 2) Can not be calibrated across the point, otherwise there is an alarm warning of "uncalibrated gain of the previous point". If the **3-point** calibration is used, it is necessary to calibrate the calibration point **1**, the calibration point **2** and the calibration point **3**, but it is not possible to calibrate the calibration point **3** and the calibration point **4** after completing the calibration point **1**.
- 3) When the multi-point calibration, the weight weight needs to increase, such as the weight of the weight of the calibration point **2** must be greater than the weight of the calibration point **1**, otherwise the alarm of "the weight calibration is less than the previous point" will appear.

### 3.3.4 Theory Calibration

Calibration with theoretical value refers to the weight calibration operation through the input to connect the loadcell sensitivity and loadcell range value.

Calibration with theoretical value requires **3** steps:

- 1) Set the Loadcell sensitivity (such as connecting multiple loadcells, input the average sensitivity)
- 2) Set the total loadcell capacity (if connecting multiple loadcells, enter the total loadcell range)
- 3) Turn on the Use T-CAL switch.

## 3.4 IO module

### 3.4.1 Input

The standard instrument is equipped with 5 input ports, each input port can be set separately application function, mode (high and low levels are valid), debounce time.

Input port unified level mode, that is, set IN1 mode to high level, then IN2~IN5 set to high level at the same time.

Parameter Items	Parameter content	Instructions
Input (IN1 to IN5)	Input CFG	Optional functions:None, Zero,CAL Zero, Clear Tare, Gross/Net, Pint, Feed Paper,Start, Stop ※ Defined as no function, that is, the input port has no effect.
	Input mode	Initial value: Low level; Optional: High level, low level <b>(Note: the input port mode changes synchronously, that is, IN1~IN5 changes the mode, and other inputs change accordingly, keeping the input port mode consistent.)</b>
	Delay Time	Avoid misjudgment from signal shake. Initial value: <b>5ms</b> ; Range : <b>0-200ms</b>

Input port function description:

Application function	Meaning
None	No input
Zero	When the signal input is valid, the instrument performs zero.
CAL Zero	When the signal input is valid, the instrument performs zero calibration.
Clear Tare	When the signal input is valid, the tare function is performed.
Gross/Net	When the signal input is valid, the gross/net weight is switched.
Print	When this signal input is valid, the print function is performed.
Feed Paper	In the non-print state, when the signal input is valid, print feed paper for 1 line.
Start	When this signal is valid, the instrument will enter the operating state. This input is a pulse input signal.
Stop	When this signal is valid, the instrument will return to the stop state. This input is a pulse input signal.
Manually complete	When the signal input is valid, the manual batching of the current material is completed.

### 3.4.2 Output

Each output can be set separately application function, mode (high and low levels are valid). The initial default is no output, the output port can set the high and low level mode separately, which needs to be defined by the customer.

Parameter Items	Parameter content	Instructions
	Output CFG	Optional functions: No function, stable, zero, communication heartbeat, weighing OK, ready;

Output (OUT1-OUT 9)		※ Defined as no function means that the output port has no function.
	Output mode	Initial value: Low; Optional: High, low (Note: Only output OUT1-OUT5 supports mode switching, OUT6-OUT9 is relay output and does not support mode switching)

#### Output Port function description

Application function	Meaning
None	No output
Stable	Valid when the instrument stability marker bit has an output.
Zero	Instrument zero indicator is valid when there is an output.
Net	The output is valid when the instrument is at net weight.
Printing	The output is valid when the instrument is in the printing process.
-SIGN	There is output when the displayed weight is less than 0.
Batching	The output is valid when the instrument is in the batching process.
Over	Output when the weight of the material exceeds the upper limit.
Pass	Output when the weight of the material between weight equal to the target value.
Under	Output when the material weight is lower than the lower limit.
Material Done	When the current material reaches the target value and you click "Done", this signal output is valid.
Batch Complete	This signal is output effectively after all the set materials have been prepared.

### 3.4.3 I/O test

This item can check whether the output and input interfaces of the instrument and external devices are connected normally through the IO test. Before the IO test, the **test switch** is opened first, and then the output and input port test is performed.

**OUT1~OUT9 test:** In the I/O test interface, perform the output test. That is, after clicking the corresponding output port button, the interface port color will light up, and the corresponding external connection output state should be valid. If it is invalid, it indicates that the connection is abnormal.

**IN1~IN5 test:** In the IO test interface, when the external input signal is valid, the color of the corresponding input definition port under the interface is lit up as green. When the external input is valid, the interface does not respond, it indicates that the connection is abnormal. Check the power input and wiring of the IO.

## 3.5 Recipe Setting

You can click "Recipe" in the function key area of the main interface or in the menu interface to enter the recipe parameter interface for Settings.

Parameter Items	Meaning
Recipe ID	Initial value: 1; Range: 1-10, Up to 10 sets of recipes are supported.
Recipe Name	Customizable recipe names are available.
Tare	On and off options are available. When the current recipe is enabled, it

Before	will automatically perform a taring operation before each ingredient filling. If it is turned off, no taring will be performed.
Material Type	Initial value:20; Range:1-20. The number of materials can be set. The interface will display as many groups of material parameters as the number of materials is set. The parameters of each group of materials are as follows
<b>Group 1~20 Material Parameters</b>	
Material Name	The name of the material can be customized. Only supports 10 characters
Target	target value. Initial value: 0 Range: 0 to maximum range.
Up Limit	Based on the target value, set the upper limit value of the material and the allowable deviation range of the material weight.
Low Limit	Based on the target value, set the lower limit value of the material and the allowable deviation range of the material weight.

### 3.5.1 Recipe Interface Description

The recipe interface is shown in the following figure. When the number of materials is set, the number of material parameter boxes will be displayed. The target value (T), upper limit (H), and lower limit (L) are displayed in each group of material parameters. Click on the corresponding material parameter box to set the material name, target value, and upper and lower limit values for each group of materials.

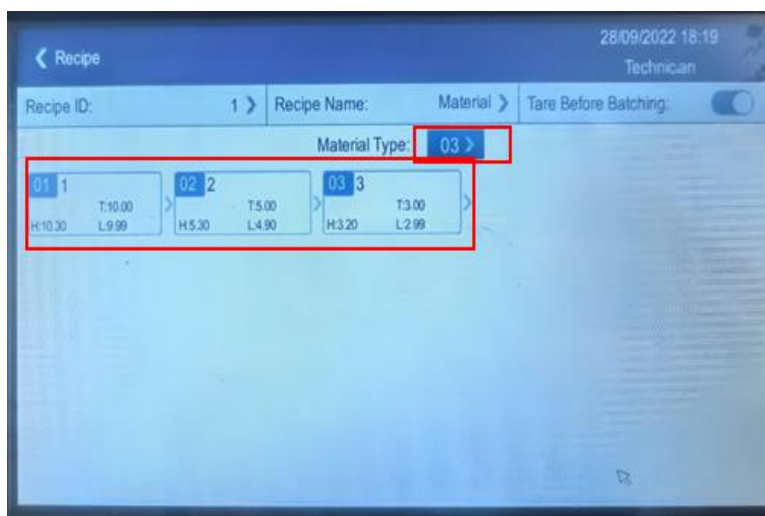

### 3.5.2 Description of Batching process

【CAL Done】→【Set Recipe】→【Set Material Type】→【Set Target Value and Up/Low Limit】→【Return the main interface】→【Click Start】→【Start feeding from Material 1 and observe when the weight reaches the target value of Material 1】→【Click Done】→【Then proceed with the manual batching of other materials, following the same steps as Material 1】→【Until all the materials are completed, a pop-up window will prompt that the ingredients are ready】→【then a historical record will be output】

### 3.6 Communication Settings

GMC-P7(F8) has a rich communication function interfaces: **2 RS485 (serial port 1, serial port 2)**. Serial port connection refer [to Section 2.5](#).

#### 3.6.1 Serial Port Parameters

Communication Parameters	Parameter Sub item	Instructions
COM1/ COM2/ COM3	Slave ID	Initial value: <b>01</b> ; Range: <b>01-99</b>
	Baudrate	Initial value: <b>38,400</b> ; Range: <b>1200,2400,4800,9600,19200,38400,57600,115200</b> (Note: Only 9600~115200 is supported under the Print protocol)
	Protocol	Initial value: <b>Modbus RTU</b> ; Range: <b>Modbus RTU, Modbus ASCII, Cont-A</b> (continuous transmit-CB920), Cont-B (continuous transmit-TT), <b>r-Cont, rE-Cont, YH, Print(print)</b>
	Data Format	Initial value: <b>8-E-1</b> ; Range: <b>8-n-1, 8-e-1, 8-o-1, 7-e-1, 7-o-1</b> (Note: Modbus protocol and Print protocol only support data formats with 8-bit data bits)
	Dword	Initial value: <b>AB-CD</b> ; Range: <b>AB-CD</b> (high byte before), <b>CD-AB</b> (low byte before)
	Send Gap	The time interval between frames under the continuous transmission protocol. Initial value: 20ms; Range 0-1000ms.

#### 3.6.2 Network Port Parameters

Network Port Parameters (Optional network port expansion board,this parameter can be seen)	Local IP	Initial value: <b>192.168.0.100</b> , range: <b>0.0.0.0 to 255.255.255.255</b> .
	Protocol	<b>Initial value: Modbus/TCP</b> ; When selecting a common network port, the protocol is optional: <b>Modbus/TCP,Cont-A/TCP,Cont-B/TCP,r-Cont/TCP, rE-Cont/TCP, YH/TCP</b>
	Socket	Initial value: <b>502</b> ; Range: <b>1-65535</b> .
	Dword	Initial value: <b>AB-CD</b> ; Range: <b>AB-CD</b> (high byte firstly), <b>CD-AB</b> (low byte firstly)
	Send Gap	Initial value: <b>20ms</b> ; Range: <b>0 to 1000</b> .

#### 3.6.3 Peripherals Parameters

Print	Content	Initial value:Simple 1; Simple 1/Simple 2/Detail are optional.For specific details, please refer to the application examples of printing formats.
	Ticket Gap	Initial value: <b>2</b> ; Number of lines spaced between each print, range: <b>0-99</b>
	Printer Model	Initial value: Epson LX-310, optional: Epson LX-310, Weihuang WH-E26.

When the communication protocol of serial port parameter "Print", under the main interface, set the input as print to print the instrument data.

### Print format setting application example:

#### Detail:

Printed content includes: recipe name, cumulative target weight of the recipe, cumulative actual weight of the recipe, cumulative net weight of the recipe, cumulative gross weight of the recipe, instrument date, start and end time of batching, total batching time, material name, target weight of the material, actual weight of the material

Note: The printing of the material name, target weight of the material, and actual weight of the material should be printed according to the number of material groups in the actual recipe number.

```
@Recipe name          N/A
-----
Tgt.value             +1600kg
Act.value             +2012kg
Net weight            +2012kg
Gross weight          +2012kg
Date                  27/09/2022
Start time            15:16:51
Final time            15:17:06
Spent                  15s
-----
Material1
Tgt.value             +600kg
Act.value             +907kg
Material2
Tgt.value             +400kg
Act.value             +501kg
Material3
Tgt.value             +600kg
Act.value             +604kg
```

#### Sample 1:

Printed content includes: recipe name, cumulative target weight of the recipe, cumulative actual weight of the recipe, cumulative net weight of the recipe, cumulative gross weight of the recipe, instrument date, material name, target weight of the material, actual weight of the material

Note: The printing of the material name, target weight of the material, and actual weight of the material should be printed according to the number of material groups in the actual recipe number. The style reference is as follows:

@Recipe name	N/A
Tgt.value	+1600kg
Act.value	+2612kg
Net weight	+2612kg
Gross weight	+2612kg
Date	27/09/2022
Material1	
Tgt.value	+600kg
Act.value	+805kg
Material2	
Tgt.value	+400kg
Act.value	+603kg
Material3	cgzy
Tgt.value	+600kg
Act.value	+1204kg

### Sample 2:

Printed content includes: recipe name, cumulative target weight of the recipe, cumulative actual weight of the recipe, cumulative net weight of the recipe, cumulative gross weight of the recipe, and instrument date

The style reference is as follows:

@Recipe name	N/A
Tgt.value	+1600kg
Act.value	+2513kg
Net weight	+2513kg
Gross weight	+2513kg
Date	27/09/2022

## 3.7 History Record

On the main interface, click on [History] to enter this interface. Under the "History" parameter, users can view the cumulative recipe and the historical records of ingredients, as well as the upper and lower limit values of the target values set for each material. At the same time, historical records can be exported to a USB flash drive or data can be cleared, etc.

Click [Clear Data], and a pop-up window confirms the clearing of all historical data.

Click [U Disk Export], pop-up window confirmation can export all historical record data.

## 3.8 Maintenance

This parameter is used to reset the instrument and modify system parameters. Perform this operation with caution and log in as an administrator

※ **Note: log in as an administrator to view the system maintenance parameters.**

### 3.8.1 Parameter Description

Maintenance	Parameter Sub item	Instructions
Display Style	System Language	Set the system language. Initial value: Chinese; Chinese, English optional.
	Date&Time	Set the instrument to display time.
	Main Display Style	Style 1 and Style 2 are optional. Initial value: Style 1
	Backlight Switch	Turn on the backlight switch, which will turn off the screen.
	Backlight Time	Turn on the backlight switch and set the backlight time. When the time arrives, the instrument will display and click the screen to light the screen again. Initial value: <b>15s</b> , range: <b>15 to 1800s</b> .
COM Test	Send test	Refer <a href="#">to Chapter 3.8.3 COM Test for details</a> .
	Receive Test	
System Info	MAC	View the <b>MAC</b> address of the instrument, which can only be queried but not modified
	Serial No.	View the serial number, which can only be queried and cannot be modified
	Change User Password	Use this item to change the technician password.
	<b>138</b> No.	Displays the <b>138</b> number of the instrument, which can only be queried and cannot be modified
	V Corr Factor	Default: <b>1.0000</b> ; Used to calibrate the input voltage of the instrument loadcell. It can only be queried but not modified
	Remote CAL	Initial value: Off; On or off optional. This enables remote calibration of the instrument through communication.
Reset parameters	Reset all parameters	Restore all parameters to the factory Settings.
	Reset all parameters (except calibration)	Restore parameters other than calibration to their factory Settings.
	Reset calibration parameters	Click this item to restore the calibration parameters to the factory Settings.
	Reset application parameters	Click this item to restore application parameters to the factory Settings.
	Reset communication parameters	Click on this item to restore the communication Settings parameter value to the factory Settings
	Reset basic parameters	Click on this item to restore the basic parameters to the factory Settings

	Reset IO function	Click on this item to restore the value of the IO definition parameters to the factory setting.
Upgrade	The front and back ends of the instrument and the startup interface can be upgraded and modified via a USB flash drive. For details, please refer to <a href="#">Section 3.8.4</a> .	

### 3.8.2 Display Style Description

#### 3.8.2.1 Style 1

1. Style 1 is shown in the following figure. Above the weight display on the main interface is the qualified range, which is [material target value - lower limit, material target value + upper limit]. Below the weight display is the current weight progress bar of the material.
2. The entire progress bar length corresponds to 0- (target value of the material + upper limit + lower limit), and the arrow on the progress bar indicates the current target value of the material. When the progress bar is filled with green, it indicates that the current weight is within the qualified range. If the progress bar is filled with orange, it indicates that the current weight is below the lower limit value. If the progress bar is filled with red, it indicates that the current weight is higher than the upper limit value.

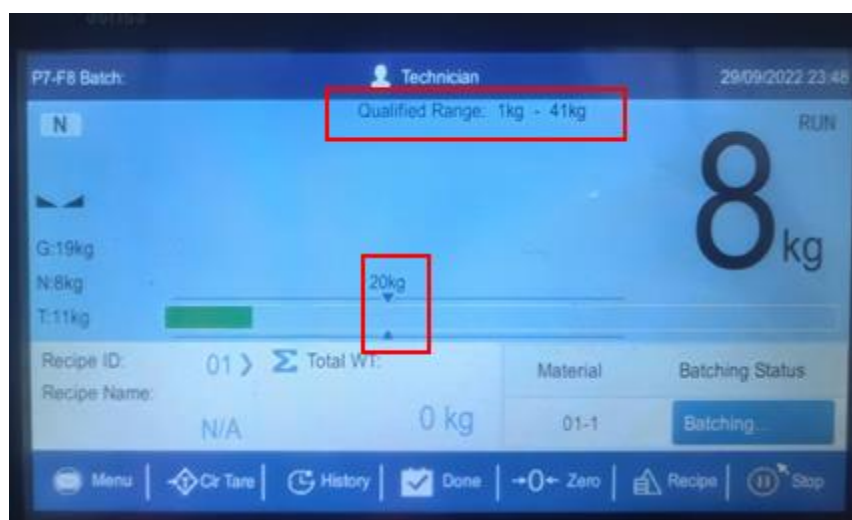

#### 3.8.2.2 Style 2

1. Style 2 is shown in the following figure. Below the weight display on the main interface is the qualified range, which is [material target value - lower limit, material target value + upper limit].
2. When the background color for displaying the weight is green, it indicates that the current weight is within the qualified range. If the background color is orange, it indicates that the current weight is below the lower limit value. If the background color is red, it indicates that the current weight is above the upper limit value.

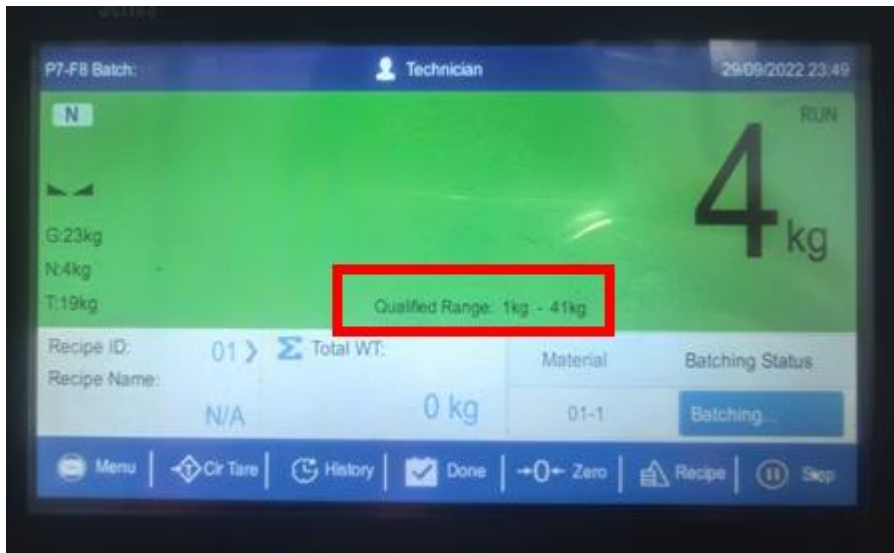

### 3.8.3 COM Test

The function of serial port test is to send and receive data in cyclic transmission mode, fixed baud rate (9600), data format (8-N-1) and 1s transmission interval to test the status of serial port connection.

**Send Test:** Send data "COMx Test nnn". X=1 if serial port 1, X=2 if serial port 2 test.

**Receive test:** The external sends test data (only ASCII code) to the instrument and displays the data on the display, with no more than 10 bytes of data per frame.

If the external sends **30 31 41** to the instrument, and the instrument displays the following figure, it indicates that serial port **1** is connected normally.

```
COM 1:001 A 0D
COM 2:
COM 3:
```

### 3.8.4 USB Drive Upgrade software

Under the technician's authority, the instrument can be upgraded from the front to the back end and the startup interface can be changed through the Menu - Maintenance - Upgrade interface. The specific operation steps are as follows.."

#### 3.8.4.1 Front-end upgrade

1.	Plug the pen driver containing the upgrade kit "tpcbakup" into the instrument;
2.	Pop-up "the mcgsTpc USB flash drive comprehensive function package, click 'Yes' to enter the system setting interface and start the comprehensive function package, click' No 'to exit", click' yes' to pop up "User project update button"
3.	Click the "User Project Update" button, select the project to start downloading
4.	The download automatically restarts after upgrading successfully.

#### 3.8.4.2 Back-end upgrade

The steps are as follows

1.	Insert the U disk into the computer, and create a folder "GMC-P7 (F8)" in the U disk;
2.	Store the "GMC-P7(F8)-Upload.gm" file in the "GMC-P7(F8)" folder;

3.	Insert the U disk into the instrument, enter the system information interface of the system maintenance of the instrument (administrator permission is required), press <b>3s in the lower left blank</b> , GMC-P7(F8) online upgrade interface appears, click to jump to the upgrade home button, jump to the upgrade interface, click upgrade, click upgrade again, the word "under upgrade" appears, indicating that the instrument is upgrading back end
4.	Wait for the progress bar to finish, countdown <b>10s</b> after the upgrade successfully jump to the startup login interface

### 3.8.4.3 Upgrade Startup Screen

Here are the steps:

1.	Save the (resolution 800*480, format.bmp) picture file and boot interface project package (tpcbakcup) to the root directory of the USB flash drive; ( <b>Note: this project package tpcbakcup and the front end upgrade kit tpcbakcup upgrade is not the same file</b> )
2.	Insert the USB flash drive into the instrument;
3.	The instrument pops up the display box of "device vendor U disk toolkit", select "Update startup bitmap"
4.	Enter the Logo selection interface, select the picture to be upgraded, click OK, prompting to restart after the successful update of the bitmap.

## 3.9 Working parameters

Parameter item	Instructions
Ingredient Mode	Initial value: 0; Range: 0 - Manual batching, 1 - Automatic batching.
Delay setting time	When the current weight is within the qualified range, the stability value will be judged after this delay period Initial value: 0.5s Range: 0.0 - 999.9s.

## 3.10 Communication protocol and address

### 3.10.1 Modbus Protocol

#### 3.10.1.1 Function Code and Exception Code Description

Function codes supported by the instrument

Function code	Name	Instructions
<b>03</b>	Read register	Read up to <b>125</b> registers at a time
<b>06</b>	Write a single register	Use this function code to write a single holding register.
<b>16</b>	Write multiple registers	This instrument command only supports writing double registers, the address must be aligned when writing, only a part of the double register is not allowed to be written, and a part of the read is allowed when reading.
<b>01</b>	Read Coil	Note that this length is in bits.
<b>05</b>	Write Coil	

Note: This instrument only supports the above **MODBUS** function codes, the instrument will not respond when sending other function codes to the instrument.

Exception Code response

Code	Name	Meaning
<b>02</b>	Illegal data	For this instrument, this error code indicates that the received

	address	data address is a disallowed address.
<b>03</b>	Illegal data value	The written data does not conform to the allowed range.
<b>04</b>	Slave machine failure	An unrecoverable error occurs when the instrument is attempting to perform the requested operation.
<b>07</b>	An unsuccessful programming request	For the instrument, the command received cannot be executed under the current conditions.

### 3.10.1.2 Transmission mode

#### RTU Mode

(1) When communicating in **RTU** mode, every **8** bits (**1** byte) in the message is divided into two **4-bit hexadecimal** characters.

(2) Indicates an interval of more than 3.5 characters at the end of a frame. For a more reliable end, it is recommended to use an interval of more than **4.0** characters.

#### The specific protocol is as follows:

Supported data formats: 8-bit data bit, 1-bit stop bit, parity check (**8-E-1**)

8-bit data bit, 1-Stop Bit, Odd check (**8-O-1**)

8 Data bits, 1 Stop Bit, no check (**8-N-1**)

Code: Binary

#### ASCII mode

When communicating in ASCII mode, every **8** bits (**1** byte) in a message is transmitted as 2 ASCII characters.

#### The specific protocol is as follows:

Supported data formats: 8-bit data bit, 1-bit stop bit, parity check (**8-E-1**)

8-bit data bit, 1-Stop Bit, Odd check (**8-O-1**)

8 Data bits, 1 Stop Bit, no check (**8-N-1**)

Code: ASCII code

### 3.10.1.3 Modbus Communication Address Table

PLC address	Display address	Meaning	Instructions	
<b>Weight status information parameters</b>				
<b>40001-40002</b>	<b>0000-0001</b>	Current weight value (4 bytes signed integer)		
<b>40003-40004</b>	<b>0002-0003</b>	Reserved		
<b>40005</b>	<b>0004</b>	Weight status flag bit	Bit	Instructions
			<b>D13-15</b>	Reserved
			<b>D12</b>	Bipolar
			<b>D11</b>	Reserved
			<b>D10</b>	ADC failure
			<b>D09</b>	Current display net weight
			<b>D08</b>	Millivolts stable
			<b>D07</b>	Loadcell negative overflow
			<b>D06</b>	Loadcell positive overflow
<b>D05</b>	Weight			

※ Indicates the weight status of the instrument, when it is the current state, the status bit shows "1". If the current weight is zero and stable, the address **D0D1** status bit is "1"

				negative overflow	
			<b>D04</b>	Weight positive overflow	
			<b>D03</b>	Overflow status	
			<b>D02</b>	Display weight is negative	
			<b>D01</b>	Zero	
			<b>D00</b>	Stable	
<b>40006</b>	<b>0005</b>	Error Code 1	<b>D11-15</b>	Reserved	
			<b>D10</b>	The previous weight point is not calibrated	
			<b>D09</b>	Exceed the minimum resolution	
			<b>D08</b>	Weight input exceeds maximum range	
			<b>D07</b>	The weight input cannot be zero	
			<b>D06</b>	Weight calibration is less than zero or the previous calibration point	
			<b>D05</b>	The loadcell overflow positively when Weight calibration	
			<b>D04</b>	The Loadcell overflow negatively when weight calibration	
			<b>D03</b>	Unstable during weight calibration	
			<b>D02</b>	Loadcell overflow positively at zero calibration	
			<b>D01</b>	Loadcell overflow negatively during zero calibration	
			<b>D00</b>	Unstable during zero calibration	
			<b>40007</b>	<b>0006</b>	Error Code 2
<b>D11</b>	The weight is negative when clearing tare				
<b>D10</b>	Loadcell overflow positively when taring				
<b>D09</b>	loadcell overflow negatively when taring				
<b>D08</b>	Unstable when taring				
<b>D07</b>	The net weight status does not allow zeroing				
<b>D06</b>	The remote zero switch is not enabled during remote zero				
<b>D05</b>	Loadcell overflow positivly when zeroing				
<b>D04</b>	Loadcell overflow negativly when zeroing				
<b>D03</b>	Unstable when zeroing				
<b>D02</b>	Zero out of range				
<b>D01</b>	Zeroing unstable during power-				

				on
			<b>D00</b>	The power-on zero is out of range
<b>40008-40018</b>	<b>0007-0017</b>	Reserve		
<b>40019-40020</b>	<b>0018-0019</b>	Gross weight value (4 bytes of signed integer)		
<b>40021-40022</b>	<b>0020-0021</b>	Net weight value (4 bytes of signed integer)		
<b>40023-40024</b>	<b>0022-0023</b>	Tare value (4 bytes of signed integer)		
<b>40025-40026</b>	<b>0024-0025</b>	Reserved		
<b>40027-40028</b>	<b>0026-0027</b>	Display weight value (floating point type)		
<b>40029-40030</b>	<b>0028-0029</b>	Gross weight value (4 bytes signed floating point number)		
<b>40031-40032</b>	<b>0030-0031</b>	Net weight value (4 bytes signed floating point number)		
<b>40033-40034</b>	<b>0032-0033</b>	Tare value (4 bytes signed floating point number)		
<b>40035-40036</b>	<b>0034-0035</b>	Reserve		
<b>40037-40038</b>	<b>0036-0037</b>	<b>AD</b> Internal Code after filtering	Internal code of ADC after filtering, Bipolar - signed number; Unipolar - unsigned number	
<b>40039-40040</b>	<b>0038-0039</b>	Loadcell voltage value	Signed numbers, integer, four decimal points	
<b>40041-40042</b>	<b>0040-0041</b>	Voltage value relative to zero point	Signed number, integer, four decimal points	
<b>40043 ~ 40091</b>	<b>0042-0090</b>	Reserve		
<b>40092</b>	<b>0091</b>	Input status area	<b>Bit</b>	<b>Instructions</b>
			<b>D05-15</b>	Reserve
			<b>D04</b>	Input <b>5</b> status
			<b>D03</b>	Input <b>4</b> status
			<b>D02</b>	Input <b>3</b> status
			<b>D01</b>	Input <b>2</b> status
<b>D00</b>	Input <b>1</b> status			
<b>40093</b>	<b>0092</b>	Reserve		
<b>40094</b>	<b>0093</b>	Output status area	<b>Bit</b>	<b>Instructions</b>
			<b>D09-15</b>	Reserve
			<b>D08</b>	Output <b>9</b> status
			<b>D07</b>	Output <b>8</b> status
			<b>D06</b>	Output <b>7</b> status
			<b>D05</b>	Output <b>6</b> status
			<b>D04</b>	Output <b>5</b> status
			<b>D03</b>	Output <b>4</b> status
			<b>D02</b>	Output <b>3</b> status
<b>D01</b>	Output <b>2</b> status			
<b>D00</b>	Output <b>1</b> status			
<b>40095 ~ 40100</b>	<b>0094~0099</b>	Reserve		
<b>Basic parameter area, readable-writable</b>				
<b>40101-40102</b>	<b>0100-0101</b>	Power-on zero range	0%-99% of the maximum range, initial value: 0 (off)	
<b>40103-40104</b>	<b>0102-0103</b>	Remote zero switch	Range: <b>0</b> (off), <b>1</b> (on); Initial value: <b>1</b> (on)	
<b>40105-40106</b>	<b>0104-0105</b>	Zero range	1%-99% of the maximum range, initial value: 20%	
<b>40107-40114</b>	<b>0106-0113</b>	Reserve		
<b>40115-40116</b>	<b>0114-0115</b>	Stable range	Range: <b>0-99d</b> , initial value: <b>1</b>	

40117-40118	0116-0117	Stable time	Range: <b>1-5000</b> milliseconds, initial value: <b>1000</b>
40119-40120	0118-0119	Tracking zero range	Range: <b>0-99d</b> , initial value: <b>1</b>
40121-40122	0120-0121	Tracking zero time	Range: <b>1-5000</b> milliseconds, initial value: <b>1000</b>
40123-40124	0122-0123	Digital filtering	Range: <b>0-9</b> , initial value: <b>8</b>
40125-40126	0124-0125	Steady State filtering	Range: <b>0-99d</b> , initial value: <b>8</b>
40127-40128	0126-0127	AD Sampling speed	Range: <b>0-9</b> (corresponds to <b>0-50; 1-60; 2-100; 3-120; 4-200; 5-240; 6-400; 7-480; 8-800; 9-960</b> ); Initial value: <b>6-400Hz</b>
40129-40130	0128-0129	Signal range	Range: <b>0-5</b> (corresponds to <b>0:0-5mV; 1:0-10mV; 2:0-15mV</b> .) Initial value: <b>1 (0-10mV)</b>
40131 ~ 40200	0130~0199	Reserve	
<b>Calibration parameter area, remote calibration switch in system information (readable and writable), otherwise read only</b>			
40201-40202	0200-0201	Unit	Range: <b>0-3; 0-t, 1-kg, 2-g, 3-lb</b>
40203-40204	0202-0203	Decimal point	Range: <b>0-4; 0-0, 1-0.0, 2-0.00, 3-0.000, 4-0.0000</b>
40205-40206	0204-0205	Division value	Range: <b>1,2,5,10,20,50,100,200,500</b>
40207-40208	0206-0207	Capacity	Range: <b>0- Division value *200000</b>
40209-40210	0208-0209	Reserve	
40211-40212	0210-0211	Automatic zero calibration	Write <b>1</b> only; Write <b>1</b> to calibrate zero of the current state. Read: Current millivolts of the loadcell. Fix:4 decimal points.
40213-40214	0212-0213	Manual zero calibration	Range: <b>0-150000</b> ; Write millivolts
40215-40216	0214-0215	Calibration point 1	Write weight value to calibrate weight calibration point 1
40217-40218	0216-0217	Calibration point 2	Write weight value to calibrate weight calibration point 2
40219-40220	0218-0219	Calibration point 3	Write weight value to calibrate weight calibration point 3
40221-40222	0220-0221	Calibration point 4	Write weight value to calibrate weight calibration point 4
40223-40224	0222-0223	Calibration point 5	Write weight value to calibrate weight calibration point 5
40225-40226	0224-0225	LC mV/V	Initial value: 2.0000; Range: 0.000- 3.9999 The true sensitivity of the loadcell, with four decimal points. If there are multiple loadcells, it is the average sensitivity
40227-40228	0226-0227	LC Capacity	Initial value: 10,000 Range: 0 to maximum range. The true range of the loadcell is the sum of the ranges of all loadcells if there are multiple loadcells.
40229-40230	0228-0229	Use T-CAL	Writing <b>1</b> enables theoretical value calibration, and writing <b>0</b> uses calibration data
40231-40232	0230-0231	Correction Factor	The write coefficient corrects the calibration.

			The written data is integer, and the system defaults to having five decimal points for the written data.
<b>40233~40300</b>	<b>0232~0299</b>	Reserve	
<b>Application parameter area, readable and writable</b>			
<b>40301-40302</b>	<b>0300-0301</b>	Mode selection	0- Manual batching mode
<b>40303-40304</b>	<b>0302-0303</b>	Input 1 Function	Comparing modes: Range: <b>0-8, 0-None, 1-Zero, 2-CAL Zero, 3-Clear Tare, 4-Gross/Net, 5-Print, 6- Feed Paper, 7-Start, 8-Stop</b>
<b>40305-40306</b>	<b>0304-0305</b>	Input 1 Mode	Range: <b>0-1, 0: Low Level, 1: High Level</b> , (Note: Input 1 mode changes synchronously with input 2/3 mode, that is, as long as you change the mode of one input port, the other two input modes change accordingly)
<b>40307-40308</b>	<b>0306-0307</b>	Input 1 Delay Time	Parameter range: <b>0-200ms</b> , initial value: <b>5ms</b>
<b>40309-40310</b>	<b>0308-0309</b>	Input 2 Function	Refer to Input 1 function description
<b>40311-40312</b>	<b>0310-0311</b>	Input 2 Mode	Refer to Input 1 mode instructions
<b>40313-40314</b>	<b>0312-0313</b>	Input 2 Delay Time	Refer to Input 1 debounce instructions
<b>40315-40316</b>	<b>0314-0315</b>	Input 3 Function	Refer to Input 1 function description
<b>40317-40318</b>	<b>0316-0317</b>	Input 3 Mode	Refer to Input 1 mode instructions
<b>40319-40320</b>	<b>0318-0319</b>	Input 3 Delay Time	Refer to Input 1 debounce instructions
<b>40321-40322</b>	<b>0320-0321</b>	Input 4 Function	Refer to Input 1 function description, can only be written when there is an <b>IO</b> attach board, otherwise read only
<b>40323-40324</b>	<b>0322-0323</b>	Input 4 Mode	Refer to Input 1 mode description, can only write when there is an <b>IO</b> attach board, otherwise read only. (Note: the additional input 1 mode changes synchronously with the additional input 2 mode, that is, as long as the mode of one input port is changed, the other input port mode changes accordingly)
<b>40325-40326</b>	<b>0324-0325</b>	Input 4 Delay Time	Refer to Input 1 debounce instructions
<b>40327-40328</b>	<b>0326-0327</b>	Input 5 Function	Refer to Input 1 function description
<b>40329-40330</b>	<b>0328-0329</b>	Input 5 Mode	Refer to Input 1 mode instructions
<b>40331-40332</b>	<b>0330-0331</b>	Input 5 Delay Time	Refer to Input 1 debounce instructions
<b>40333-40334</b>	<b>0332-0333</b>	Output 1 Function	Range <b>0-11</b> , corresponding to: <b>0- None, 1- Stable, 2-Zero, 3-Net, 4-Printing, 5- -SIGN, 6-Batching, 7-Over, 8-Pass, 9-Under, 10-Material Done, 11-Batch Complete.</b>
<b>40335-40336</b>	<b>0334-0335</b>	Output 1 Mode	Range: <b>0-1, 0: Low Level, 1: High Level.</b>
<b>40337-40338</b>	<b>0336-0337</b>	Output 2 Function	Refer to Output 1 function
<b>40339-40340</b>	<b>0338-0339</b>	Output 2 Mode	Refer to Output 1 mode
<b>40341-40342</b>	<b>0340-0341</b>	Output 3 Function	Refer to Output 1 function
<b>40343-40344</b>	<b>0342-0343</b>	Output 3 Mode	Refer to Output 1 mode
<b>40345-40346</b>	<b>0344-0345</b>	Output 4 Function	Refer to Output 1 function
<b>40347-40348</b>	<b>0346-0347</b>	Output 4 Mode	Refer to Output 1 mode
<b>40349-40350</b>	<b>0348-0349</b>	Output 5 Function	Refer to Output 1 function
<b>40351-40352</b>	<b>0350-0351</b>	Output 5 Mode	Refer to Output 1 mode
<b>40353-40354</b>	<b>0352-0353</b>	Output 6 Function	Refer to Output 1 function

40355-40356	0354-0355	Reserve	
40357-40358	0356-0357	Output 7 function	Refer to Output 1 function
40359-40360	0358-0359	Reserve	
40361-40362	0360-0361	Output 8 function	Refer to Output 1 function
40363-40364	0362-0363	Reserve	
40365-40366	0364-0365	Output 9 function	Refer to Output 1 function
40367-40400	0366-0399	Reserve	
<b>Automatic Ingredient Mixing Parameter Area, readable and writable</b>			
40401-40402	0400-0401	Ingredient Mode	Initial value: 0; Range: 0 - Manual batching, 1 - Automatic batching.
40403-40404	0402-0403	Delay setting time	Initial value: 0.5s; Range: 0.0 - 999.9s.
40405-41000	0404-0999	Reserve	
<b>Manual batching process area, readable and writable</b>			
41001-41002	1000-1001	Manual batching function status	Read-only; 0- Idle function (i.e., stopped) 1- The function is ready to run 2- System running 3- The system is preparing to stop
41003-41004	1002-1010	The status of the manual batching process	Read-only; 0- Check startup 1- Ingredient initialization 2- In batching 3- Save the batch records 4- Completed
41005-41006	1004-1005	The recipe number for activation	Readable and writable set the reecipe group number for startup
41007-41008	1006-1007	Group 1 Start Material	Readable and writable Set the material numbers to be executed in groups 1 to 20 after startup
41009-41010	1008-1009	Group 2 Start Material	
41011-41012	1010-1011	Group 3 Start Material	
41013-41014	1012-1013	Group 4 Start Material	
41015-41016	1014-1015	Group 5 Start Material	
41017-41018	1016-1017	Group 6 Start Material	
41019-41020	1018-1019	Group 7 Start Material	
41021-41022	1020-1021	Group 8 Start Material	
41023-41024	1022-1023	Group 9 Start Material	
41025-41026	1024-1025	Group 10 Start Material	
41027-41028	1026-1027	Group 11 Start Material	
41029-41030	1028-1029	Group 12 Start Material	
41031-41032	1030-1031	Group 13 Start Material	
41033-41034	1032-1033	Group 14 Start Material	
41035-41036	1034-1035	Group 15 Start Material	
41037-41038	1036-1037	Group 16 Start Material	
41039-41040	1038-1039	Group 17 Start Material	
41041-41042	1040-1041	Group 18 Start Material	
41043-41044	1042-1043	Group 19 Start Material	
41045-41046	1044-1045	Group 20 Start Material	
41047-41048	1046-1047	Required Material numbers	Read-only; After startup, the total numbers of materials to be executed is displayed

41049-41050	1048-1049	Completed Material numbers	Read-only; After startup, the total numbers of materials that have been executed is displayed
41051-41052	1050-1051	Current Material Group	Read-only; After startup, display the current material number being executed
41053-41054	1052-1053	Recipe Accum Weight	Read-only; After startup, the cumulative weight of the ingredients that have been mixed is displayed
41055-41056	1054-1055	Current Material Weight	Read-only; After startup, the current material batching weight being executed is displayed
41057-41058	1056-1057	Recipe Start Time (Hour)	Read-only; The start time of the recipe group
41060-41061	1058-1059	Recipe Start Time (Minute)	
41062-41063	1060-1061	Recipe Start Time (Second)	
41064-41065	1062-1063	Recipe End Time (Hour)	Read-only; The end time of the recipe group
41066-41067	1064-1065	Recipe End Time (Minute)	
41068-41069	1066-1067	Recipe End Time (Second)	
41070-41071	1068-1069	Recipe Elapsed Time	Read-only; The time it takes for the recipe group to complete the use of ingredients
41072-41073	1070-1071	Previous Material Start Time (Hour)	Read-only; The start time of the recipe group.
41074-41075	1072-1073	Previous Material Start Time (Minute)	
41076-41077	1074-1075	Previous Material Start Time (Second)	
41078-41079	1076-1077	Previous Material End Time (Hour)	Read-only; The end time of the previous group of materials
41080-41081	1078-1079	Previous Material End Time (Minute)	
41082-41083	1080-1081	Previous Material End Time (Second)	
41084-41085	1082-1083	Previous Material process Time	Read-only; The time it takes for the previous group of materials to complete the batching
41086-41200	1084-1199	Reserved	
<b>Manual batching Signal area, readable and writable</b>			
41201-41202	1200-1201	Start/Stop	In idle state, write 1 to start manual batching (write 1 between 1202 and 1203 to confirm the start). In the startup state, write 1 to stop manual batching
41203-41204	1202-1203	User Confirm	When confirming for the first time, write 1 to execute the batching of

			the first group of materials. When the material batching is completed, write 1 to execute the batching of the next group of materials.
41205-41206	1204-1205	At Target Weight	Read-only; When the weight of the ingredients is equal to the target value, read it as 1; otherwise, read it as 0
41207-41208	1206-1207	Within up-limit and low-limit range	Read-only; When the weight of the ingredients is between the lower and upper limits of the material, it is read as 1; otherwise, it is 0
41209-41210	1208-1209	Material Done	Read-only; When the material is completed, output for 2 seconds and read out 1; otherwise, it is 0
41211-41212	1210-1211	Batching Complete	Read-only; When the ingredients are completed, output 1 for 2 seconds; otherwise, it is 0
41213-41214	1212-1213	Batching Overweight	Read-only; When preparing the ingredients, if the weight of the material exceeds the upper limit, read 1; otherwise, read 0
41215-41216	1214-1215	Batching Underweight	Read-only; When preparing ingredients, if the weight of the material is lower than the upper limit, read 1; otherwise, write 1 as 0 and clear the alarm status.
41217-41218	1216-1299	Reserved	
<b>Manual batching Alarm area, readable and writable</b>			
41301-41302	1300-1301	Alarm Status	Read-only; Alarm status of manual batching function; 0- Idle 1- During the start-up check, the target values of the start-up material group were not set 2- Material confirmation: The material weight is outside the upper and lower limits
41303-41304	1302-1303	Alarm handling	Write 1 to clear the alarm status
41305-41400	1304-1399	Reserved	
<b>Manual batching Tare area, readable and writable</b>			
41401-41402	1400-1401	Auto Tare For Recipe Group 1	Range: 0 (Disable)、1 (Enable); Initial value:1 (Enable); When setting to endable, the corresponding recipe group will automatically perform tare after startup confirmation, and the
41403-41404	1402-1414	Auto Tare For Recipe Group 2	
41405-41406	1404-1405	Auto Tare For Recipe Group 3	
41407-41408	1406-1407	Auto Tare For Recipe Group 4	
41409-41410	1408-1409	Auto Tare For Recipe Group 5	
41411-41412	1410-1411	Auto Tare For Recipe Group 6	
41413-41414	1412-1413	Auto Tare For Recipe Group 7	
41415-41416	1414-1415	Auto Tare For Recipe Group 8	

41417-41418	1416-1417	Auto Tare For Recipe Group 9	weight will be manually mixed in the form of net weight
41419-41420	1418-1419	Auto Tare For Recipe Group 10	
41421-41422	1420-1421	Number of Materials in Recipe Group 1	Reading and writing; Range: 1-20; Initial value: 20 The number of materials to be executed for recipe groups 1 to 10
41423-41424	1422-1423	Number of Materials in Recipe Group 2	
41425-41426	1424-1425	Number of Materials in Recipe Group 3	
41427-41428	1426-1427	Number of Materials in Recipe Group 4	
41429-41430	1428-1429	Number of Materials in Recipe Group 5	
41431-41432	1430-1431	Number of Materials in Recipe Group 6	
41433-41434	1432-1433	Number of Materials in Recipe Group 7	
41435-41436	1434-1435	Number of Materials in Recipe Group 8	
41437-41438	1436-1437	Number of Materials in Recipe Group 9	
41439-41440	1438-1439	Number of Materials in Recipe Group 10	
41441-42000	1440-1999	Reserved	
<b>Manual Batching Parameters Area</b>			
42001-42002	2000-2001	Recipe Group 1 Name1	Recipe Group Name,read-only;
42003-42004	2002-2003	Recipe Group 1 Name 2	
42005-42006	2004-2005	Recipe Group 1 Name 3	
42007-42008	2006-2007	Recipe Group 1_Material 1 Name1	Material group name, read-only
42009-42010	2008-2009	Recipe Group 1_ Material 1 Name 2	
42011-42012	2010-2011	Recipe Group 1_ Material 1 Name 3	
42013-42014	2012-2013	Recipe Group 1_ Material 1_Target	Target value of ingredient weight, range: 0 to maximum capacity, initial value: 0.
42015-42016	2014-2015	Recipe Group 1_ Material 1 Up Limit	Range: 0 to maximum range, initial value: 0.
42017-42018	2016-2017	Recipe Group 1_ Material 1 Low Limit	Range: 0 to maximum range, initial value: 0.
42019-42020	2018-2019	Recipe Group 1_ Material 2 Name 1	Refer to the modbus address 2000-2029
42021-42022	2020-2021	Recipe Group 1_ Material 2 Name 2	
42023-42024	2022-2023	Recipe Group 1_ Material 2 Name 3	
42025-42026	2024-2025	Recipe Group 1_ Material 2 Target	
42027-42028	2026-2027	Recipe Group 1 Material	

		2 Up Limit		
42029-42030	2028-2029	Recipe Group 1_ Material 2 Low Limit		
42031-42042	2030-2041	Recipe Group 1 Material 3	Refer to the parameter names and descriptions of the modbus addresses from 2006 to 2017	
42043-42054	2042-2053	Recipe Group 1 Material 4		
42055-42066	2054-2065	Recipe Group 1 Material 5		
.....	.....	.....		
42245-42246	2244-2245	Recipe Group 1_ Material 20		
42247-42248	2246-2247	Recipe Group 2 Name1	Refer to the parameter description of modbus addresses 2000 to 2245 in recipe Group 1	
42249-42250	2248-2249	Recipe Group 2 Name2		
42251-42252	2250-2251	Recipe Group 2 Name3		
42253-42254	2252-2253	Recipe Group 2_ Material 1 Name1		
42255-42256	2254-2255	Recipe Group 2_ Material 1 Name2		
42257-42258	2256-2257	Recipe Group 2_ Material 1 Name3		
42259-42260	2258-2259	Recipe Group 2_ Material 1 Target		
42261-42262	2260-2261	Recipe Group 2_ Material 1 Up Limit		
42263-42264	2262-2263	Recipe Group 2_ Material 1 Low Limit		
42265-42276	2264-2275	Recipe Group 2 Material 2		
42277-42288	2276-2287	Recipe Group 2 Material 3		
.....	.....	.....		
42481-42492	2480-2491	Recipe Group 2_ Material 20		
42493-42738	2492-2737	Recipe Group 3		Refer to the parameter description of modbus addresses 2000 to 2245 in recipe Group 1
42739-42984	2738-2983	Recipe Group 4		
42985-43230	2984-3229	Recipe Group 5		
43231-43476	3230-3475	Recipe Group 6		
43477-43722	3476-3721	Recipe Group 7		
43723-43968	3722-3967	Recipe Group 8		
43969-44214	3968-4213	Recipe Group 9		
44215-44460	4214-4459	Recipe Group 10		
44461-48000	4460-7999	Reserved		
<b>Communication parameter setting area, readable and writable</b>				
48001	8000	COM 1 Slave ID	Slave number of serial port 0; Range: 01-99	
48002	8001	COM 1 Baudrate	Initial value: 5-38400, range: 0-7 corresponding to: 0-1200, 1-2400, 2-4800, 3-9600, 4-19200, 5-38400, 6-57600, 7-115200;	
48003	8002	COM 1 Protocol	Initial value: 0-Modbus RTU, range: 0-Modbus RTU, 1-Modbus ASCII, 2-Cont-A, 3-Cont-B, 4-r-Cont, 5-rE-Cont, 6-YH, 7-Print	
48004	8003	COM 1 Data format	Initial value: 1 (8E1); Range: 0-8N1, 1-8E1, 2-8O1, 3-7E1, 4-7O1	
48005	8004	COM 1 Dword	Initial value :0 (AB-CD) Range: 0-ab-cd, 1-	

			<b>CD-AB.</b>
48006	8005	COM 1 Send Gap	Initial value: <b>20ms</b> , range: <b>0-1000ms</b>
48007~48020	8006~48019	reserve	
48021	8020	COM2 Slave ID	Refer to Serial Port <b>1</b> parameters
48022	8021	COM2 Baudrate	
48023	8022	COM2 Protocol	
48024	8023	COM2 Data format	
48025	8024	COM2 Dword	
48026	8025	COM2 Send Gap	
48027	8026	COM3 Slave ID	Default protocol: 7-Print; Refer to Serial Port <b>1</b> parameters
48028	8027	COM3 Baudrate	
48029	8028	COM3 Protocol	
48030	8029	COM3 Data format	
48031	8030	COM3 Dword	
48032	8031	COM3 Send Gap	
48033 ~ 48100	8032~8099	Reserve	
48101	8100	Network port Protocol	The protocols are <b>0-Modbus/TCP</b> , <b>1-Cont-A/TCP</b> , <b>2-Cont-B/TCP</b> , <b>3-r-Cont/TCP</b> , <b>4-rE-Cont/TCP</b> , and <b>5-YH/TCP</b> . When Ethernet/IP or Profinet is selected, this parameter cannot be set
48102	8101	Network port Dword	For standard network ports, can set <b>0-AB-CD</b> or <b>1-CD-AB</b> When <b>Ethernet/IP</b> or <b>Profinet</b> is selected, this parameter cannot be set
48103	8102	Network port send gap	This parameter can be used to set the interval for continuous transmission in other communication formats except <b>Modbus/TCP</b> . Initial value: <b>20ms</b> , the value ranges from <b>0</b> to <b>1000ms</b>
48104 ~ 48107	8103~8106	Local IP1~ IP4	Initial value: <b>192.168.0.100</b> , in order of the first to fourth part IP
48108 ~ 48111	8107~8110	Reserve	
48112	8111	Network port Socket	Initial value: <b>502</b> ;Range: <b>1-65535</b> , network communication port number Settings
48113~48200	8112~8199	Reserve	
<b>Print parameter setting area, readable-writable</b>			
48201	8200	Print Ticket Gap	Range: <b>0-99</b> , the number of lines spaced between each print
48202	8201	Print Content	Initial value: 0 Range: 0-Simple1, 1- Simple2,2-Detail
48203	8202	Print Model	Initial value: 0 0-Epson LX-310 1-WH-E26
48204~48260	8203~8259	Reserve	
48261	8260	Year (Readable and writable)	Range: 0-99
48262	8261	Month (Readable and writable)	Range: 0-12

48263	8262	Day (Readable and writable)	Range: 0-31
48264	8263	Hour (Readable and writable)	Range: 0-23
48265	8264	Minute (Readable and writable)	Range: 0-59
48266	8265	Second (Readable and writable)	Range: 0-59
48267~48280	8266-8279	Reserve	
<b>Function operation class address area (corresponding to coil function), readable-writable</b>			
48601	8600	Zero	Write 1 Perform the operation The Read are all zero
48602	8601	Tare	
48603	8602	Clear tare	
48604	8603	Gross/net weight switch	
48605	8604	CAL Zero	
48606	8605	Print	
48607	8606	Print feed paper	
48608 ~ 48900	8607 ~ 8899	Reserve	
48901	8900	Reset all parameters	Write 1 Perform the corresponding reset operation Read are all zero
48902	8901	Reset all parameters (except calibration)	
48903	8902	Reset calibration parameters	
48904	8903	Reset basic parameters	
48905	8904	Reset IO definition	
48906	8905	Reset application parameters	
48907	8906	Reset communication parameters	
48908~410000	8907-9999	Reserve	
<b>Coil address</b>			
0x0001	0000	Zero	The contents are readable and writable coils Write: FF00H = On 0000H = Off Read: 0001H = On 0000H = Off
0x0002	0001	Tare	
0x0003	0002	Clear tare	
0x0004	0003	Gross/net weight switch	
0x0005	0004	Quick Calibrate Zero	
0x0006	0005	Print	
0x0007~0x0300	0006 ~ 0299	Reserve	
0x0301	0300	Reset all parameters	This area is write only Write: FF00H = Perform reset operation Read: 0000H
0x0302	0301	Reset all parameters	

		(except calibration)	
<b>0x0303</b>	<b>0302</b>	Reset calibration parameters	
<b>0x0304</b>	<b>0303</b>	Reset Basic Parameters	
<b>0x0305</b>	<b>0304</b>	Reset IO definition	
<b>0x0306</b>	<b>0305</b>	Reset application parameters	
<b>0x0307</b>	<b>0306</b>	Reset Communication Parameters	
<b>0x0308~0x0400</b>	<b>0307-0399</b>	Reserve	
<b>0x0401</b>	<b>0400</b>	Input 1 Status	Read only area Read Return each input port status bit <b>0</b> : invalid; <b>1</b> valid
<b>0x0402</b>	<b>0401</b>	Input 2 Status	
<b>0x0403</b>	<b>0402</b>	Input 3 Status	
<b>0x0404</b>	<b>0403</b>	Input 4 Status	
<b>0x0405</b>	<b>0404</b>	Input 5 Status	
<b>0x0406~0x0450</b>	<b>0405 ~ 0449</b>	Reserve	
<b>0x0451</b>	<b>0450</b>	Output 1 status	Read only area Read Return each output status bit <b>0</b> : invalid; <b>1</b> valid
<b>0x0452</b>	<b>0451</b>	Output 2 status	
<b>0x0453</b>	<b>0452</b>	Output 3 Status	
<b>0x0454</b>	<b>0453</b>	Output 4 Status	
<b>0x0455</b>	<b>0454</b>	Output 5 status	
<b>0x0456</b>	<b>0455</b>	Output 6 status	
<b>0x0457</b>	<b>0456</b>	Output 7 Status	
<b>0x0458</b>	<b>0457</b>	Output 8 status	
<b>0x0459</b>	<b>0458</b>	Output 9 status	
<b>0x0460~0x0800</b>	<b>0459 ~ 0799</b>	Reserve	

### 3.10.2 Cont-A (continuous send -CB920)

**GMC-P7(F8)** When the serial port protocol is **Cont-A (CB920)**, data is continuously sent in the following format.

Status	,	Gross/Net	0/1	+/-	Display Values	Units	CR	LF
2-bytes	<b>2C</b>	2 bytes	<b>30/31</b>	<b>2B/2D</b>	7- bytes	2 bytes	<b>0D</b>	<b>0A</b>

Note:

Status -- 2 bytes, **OL: (4FH 4CH)** overflow; **ST: (53H 54H)** stable; **US: (55H 53H)** unstable

Gross /Net weight -- 2 bytes, **GS(gross weight) : 47H 53H; NT(net weight) : 4EH 54H;**

**0/1-1** byte, **(30H/31H)** sent alternately.

Units -- 2 bytes, such as **kg: 6BH 67H; g:20H 67H, etc**

Example: When the Instrument automatically sends the following frame of data

**53 54 2C 47 53 30 2B 20 20 20 20 32 35 34 33 39 0D 0A**

Know the current Instrument status: stable, gross weight, data value is positive, the current weight value is **254** kg

### 3.10.3 Cont-B (Continuous transmission -tt)

**GMC-P7(F8)** When the serial port protocol is set to "**Cont-B (tt)**", the collected data will be automatically sent to the PC

STX	Status 1	Status 2	Status 3	Display Values	Loadcell voltage value	CR	Checksum
02H	1 byte	1 byte	20H	6 bytes	6 bytes	0D	1 byte

Status 1:

bit7	bit6		bit5	bit4		bit3	bit2		bit1	bit0
Fixed 0	/h	1	0	t	0	0	0	0	1	0
	/m	1	1	Kg	0	1	0.0	0	1	1
				g	1	0	0.00	1	0	0
				Lb	1	1	0.000	1	0	1
							0.0000	1	1	0
Flow units			Units of weight			Decimal point				

Status 2:

bit7	bit6	bit5	bit4	bit3	bit2	bit1	bit0
Reserve	Reserve	Reserve	1- Flow	1- Unstable	1- Overflow	1- negative	1- Net weight
Fixed 0	Fixed 1	Fixed 1	0- weight	0- Stable	0- Normal	0- positive	0- Gross weight

### 3.10.4 r-Cont

**GMC-P7 (F8)** Serial port protocol is selected as "**r-Cont**", without sending any command to the weighing controller, the collected data is automatically sent to the PC in the following format.

STX	Scale No.	Fixed	Status 1	State 2	Display Values	CRC	CR	LF
02H	2- bytes	31H	1 byte	1 byte	6 bytes	2 bytes	0D	0A

Note:

Scale number - 2 bytes, ranging from 01 to 99

Status 1 -- 1 byte

bit7	bit6		bit5	bit4		bit3	bit2		bit1	bit0
Fixed 0	/h	1	0	t	0	0	0	0	0	0
	/m	1	1	Kg	0	1	0.0	0	0	1
				g	1	0	0.00	0	1	0
				Lb	1	1	0.000	0	1	1
							0.0000	1	0	0
Flow units			Units of weight			Decimal point				

State 2-1 byte

D6	D5	D4	D3	D2	D1	D0
Undefined	undefined	Gross/net weight	positive/ minus	Zero	Overflow	stable
Fixed :1	Fixed :0	Gross weight 0; Net weight 1;	0: positive 1: negative	0: Non-zero 1: zero	0: Normal 1: Overflow	0: unstable 1: Stable

Weight value - 6 bytes unsigned number; Return "Space space OFL space" when the weight is positive (negative) overflowed

**CRC** - 2 bytes, checksum

All values before the check digit are added and converted to decimal data, then the last two digits are converted to **ASCII** (tens firstly, ones after). For example:

If you have the following frame of data:

02	30	31	43	47	4F	4B	39	31	0D	0A
----	----	----	----	----	----	----	----	----	----	----

Add the sum of **02** to **4B**: **187 (Hex)** and convert to decimal **391**. It can be calculated that the check codes for this data frame are **39 and 31**.

For example:

The current instrument automatically returns data: **02 30 31 31 40 41 20 20 20 37 30 30 32 34 0D 0A**

Which can know the current status of the instrument: stable, the weight value is positive, and the current weight value is **700**.

### 3.10.5 rE-Cont

In this way, there is no need to send any command to the instrument, and the display automatically sends the collected data to the PC.

Return data frame format description:

Status	,	Content	,	+/-	Display Values	Units	CR	LF
2 bytes	2C	2 bytes	2C	2B/2D	7 bytes	2 bytes	0D	0A

Among them:

Status -- 2 bytes, **OL**(overflow):**4FH 4CH**; **ST**(stable):**53H 54H**; **US**(unstable):**55H 53H**

Content -- 2 bytes, **GS**(gross weight) : **47H 53H**; **NT**(net weight) : **4EH 54H**; **FR**(Flow): **46H 52H**

Display value - 7 bytes, including a decimal point, the front part is a space if no decimal point

Unit -- 2 bytes, such as **kg**: **6BH 67H**; **g**:**20H 67H**; **t**:**20H 74H**, etc

For example:

When the weighing display automatically sends the following frame of data:

**53 54 2C 47 53 2C 2B 20 20 20 20 38 30 38 20 74 0D 53 54 2C 47 53 2C 2B 20 20 20 20 38 30 38 20 74 0D 0A**

can see that the current status is stable, the data value is positive, and the displayed value is **808t**

### 3.10.6 YH

When the GMC-P7 (F8) communication protocol is selected as "YH", transmit data in the following format. Under this protocol, the data is output in ASCII code, and each frame data is composed of 9 groups (including decimal points). Data transmission first low then high, there is a group of delimiter "=" between each frame data, send data for gross weight, such as the current gross weight **70.15**, continuously send **51.0700=51.0700...**

For example: **123.9**

Bit0	Bit1	Bit2	Bit3	Bit4	Bit5	Bit6	Bit7	Bit8
=	9	.	3	2	1	0	0	0

Where: the high position is insufficient to fill **0**, the decimal point accounts for **1** byte, and **Bit8** is a negative sign "-" when negative.

# Chapter 4 Product Size

## 4.1 Tray Size

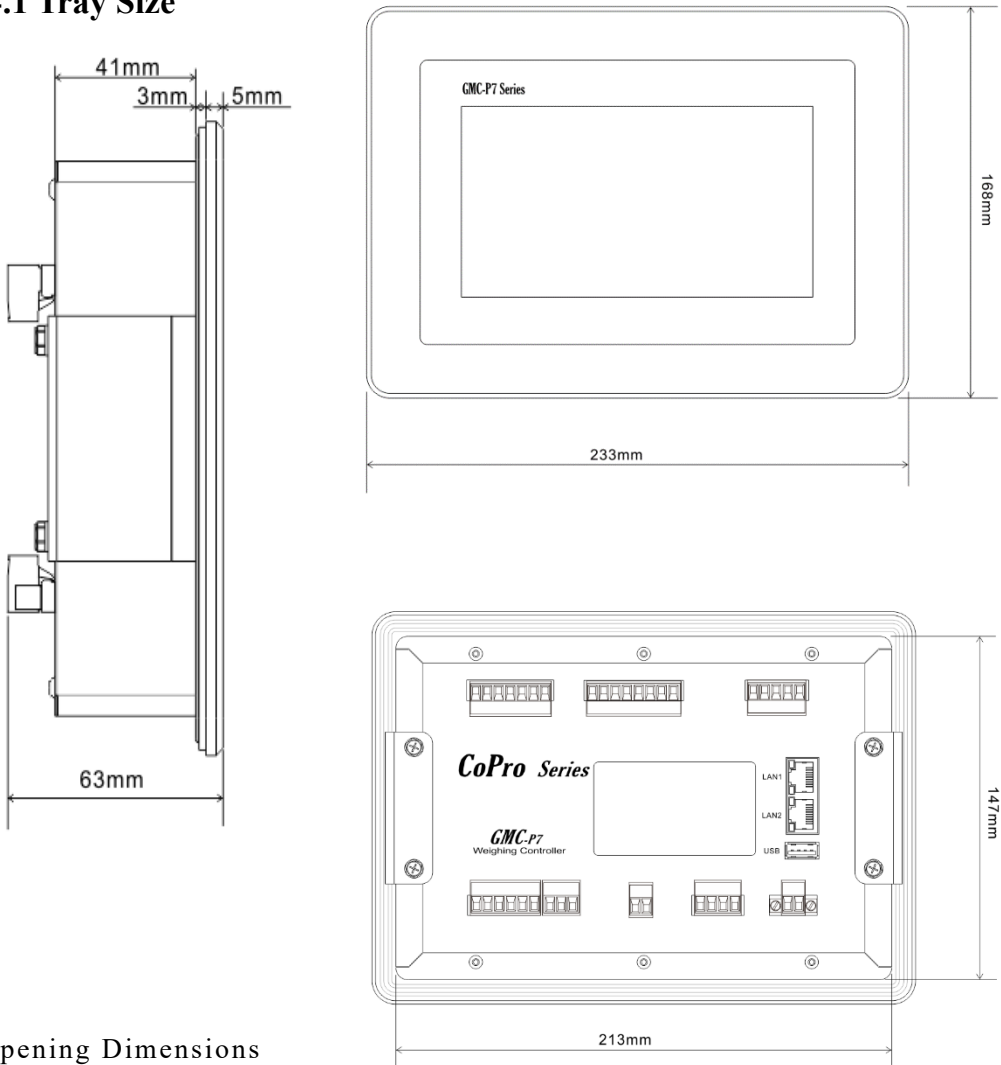

## Opening Dimensions

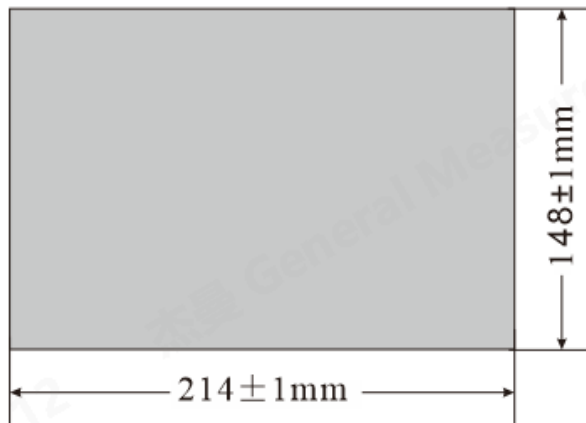

## 4.2 Desktop installation dimensions

