



杰 · 曼 · 科 · 技

G-2301P

User Manual

110615010001

V01.00.02_01

All rights reserved by Shenzhen General Measure Technology Co., LTD.
Without the permission of Shenzhen General Measure Technology Co., LTD., no unit or individual may copy, distribute, transcribe or translate into any other language in any form or by any means.



Warnings

The product is powered by a **DC24V power** supply. Using an AC220V power supply by mistake will permanently damage the instrument.

Please ensure that the instrument is properly grounded.

The product is a static-sensitive device. Please take anti-static measures during using and maintenance

**Standard &
Certification**

Product Standard: GB/T 7724-2023
Verification regulation: JJG 649-2016

Cantonese 0000000048; Safety certification: **CE**



Catalogue

Chapter 1 Overview.....	- 1 -
1.1 Product Overview and Features	- 1 -
1.2 Product parameters	- 1 -
1.3 Technical Specifications.....	- 1 -
Chapter 2 Panel and Button.....	- 3 -
2.1 Front panel instruction.....	- 3 -
2.2 Back-panel Instruction.....	- 4 -
2.3 Key Instruction.....	- 4 -
Chapter 3 Installation and Wiring.....	- 7 -
3.1 Controller Power wiring.....	- 7 -
3.2 Loadcell Connection	- 7 -
3.3 IO interface connection	- 8 -
3.4 Serial Connection.....	- 9 -
3.4.1 Serial port RS485/RS232 output.....	- 9 -
3.4.2 Troubleshooting Serial Port.....	- 10 -
3.5 Network port connection	- 10 -
3.5.1 Troubleshooting of network ports	- 11 -
3.6 Analog Connection.....	- 11 -
Chapter 4 Menu Overview	- 12 -
4.1 Setting the Flowchart.....	- 13 -
4.2 Method of setting parameters	- 13 -
Chapter 5 Weight Parameters	- 14 -
5.1 C1 Weight parameter	- 14 -
5.1.1 Zero calibration	- 15 -
5.1.2 Weight calibration	- 16 -
5.1.3 Theoretical calibration.....	- 17 -
5.2 C2 Analog calibration parameters	- 17 -
5.2.1 Analog calibration operation.....	- 17 -
5.3 C3 calibrate reset parameters.....	- 18 -
5.4 C4 calibrate the password.....	- 19 -
Chapter 6 Parameter List	- 20 -
6.1 F1 Basic Parameter list.....	- 20 -
6.1.1 Zero operation.....	- 22 -
6.1.2 Tare weight function	- 22 -
6.2 F2 Serial Port Parameter list.....	- 22 -
6.3 F3 Network port Parameter list.....	- 23 -
6.4 F4 Analog parameter list.....	- 24 -
6.5 F5 Comparator parameter list.....	- 24 -
6.5.1 Application Examples.....	- 25 -
6.6 F6 IO parameter list.....	- 27 -
6.6.1 IO Definitions.....	- 28 -
6.6.2 IO defines the operation	- 30 -
6.7 F7 Print parameter list.....	- 30 -
6.8 F8 IO and communication test.....	- 31 -
6.8.1 IO Test.....	- 31 -
6.8.2 Serial port test	- 32 -
6.9 F9 USB flash drive and register parameter list.....	- 33 -
6.9.1 U Disk import and export.....	- 34 -
6.9.2 U disk upgrade	- 34 -

6.10 F10 Maintain the list of function parameters.....	- 35 -
Chapter 7 Communication Protocol and Addresses	- 37 -
7.1 Modbus Protocol	- 37 -
7.1.1 Description of function codes and exception codes	- 37 -
7.1.2 Transmission Mode	- 37 -
7.1.3 Modbus communication Address table.....	- 38 -
7.2 RDP Protocol	- 52 -
7.3 tt Toledo Protocol	- 52 -
7.4 Easy-Cont Protocol.....	- 53 -
7.5 SP1-Cont protocol.....	- 54 -
7.6 RE-Cont Protocol	- 55 -
7.7 PROFINET communication	- 55 -
7.7.1 IO status	- 55 -
7.7.2 Device Description File GSD	- 57 -
Chapter 8 Error Code and Alarm Prompt.....	- 58 -
Chapter 9 Product Size.....	- 59 -

Chapter 1 Overview

1.1 Product Overview and Features

G-2301P is a new type of lightweight weight display with a compact design, powerful functions and reliability. It can be widely applied in various fields such as concrete mixing and asphalt mixture equipment, metallurgical blast furnaces, converters, chemical plants, and feed weight control.

- ◆ Precise appearance, equipped with **dual-screen display** and **intelligent prompts**, with detailed design that meets the needs of efficient on-site integration;
- ◆ Accurate measurement, supports **automatic weight deviation correction** to maintain consistent accuracy;
- ◆ **Rich interfaces, multiple communication protocols** to meet various signal transmission needs and achieve flexible interconnection between devices;
- ◆ **Equipped with a companion PC software**, supporting remote editing of parameters, debugging and customization of print formats;
- ◆ **USB parameter backup and migration and historical record** traceability functions, facilitating problem troubleshooting and management;
- ◆ Built-in **keyboard lock function** to prevent accidental touches by humans; can freely **set product trial lock machine** to avoid unauthorized use and ensure project property safety.

1.2 Product parameters

Shell type	Tray mounted	
loadcell interface	1 channel 6-wire analog loadcell interface, up to 8 350Ω loadcell connected	
Display	LED digital display	
Preset point function	6-channel comparator with 11 comparison methods available	
Interface	1 232/485 interface (declare when ordering)	
	USB interface for easy data import and export and software upgrade	
	4 input/10 output transistor input/output interface (4 output ports are optional and must be declared when ordering)	
	1 analog DA interface (analog is optional and must be declared when ordering)	
	Optional network port interface	Single network port
Dual network ports, built-in switch		
Profinet bus interface		

1.3 Technical Specifications

Power supply	24VDC (18 to 36VDC)
--------------	----------------------------

Shell Dimension	105*91*57(mm)
Product Weight	354g
Certified usage environment	-10 to 40 ° C; 90%R.H. Does not condense
Usage environment	-20 to 60 ° C; 90%R.H. Does not condense
Storage environment	-40 to 60°C 90%R.H. Does not condense
Load cell excitation voltage	5V 200mA(MAX)
Load cell	1 analog loadcell interface for up to 8 350Ω loadcell, supporting 1mV/V, 2mV/V, 3mV/V sensitivities
Input sensitivity	0.1 uV/d
Nonlinearity	0.01% F.S
A/D sampling rate	50; 60; 100; 120; 200; 240; 400; 480; 800; 960 (SPS)
Maximum display precision	1/999999
Keys	6-key vocal keyboard
Decimal point	6 options available, such as 1/ 0.1/0.01/0.001/0.0001/0.00001
Overload display	OFL

Chapter 2 Panel and Button

2.1 Front panel instruction





Main display: 6 digits for displaying weighing data and instrument-related information data

Status indicator:

- **ZERO:** The zero indicator is on when the weight is $0 \pm 1/4d$.
- **STAB:** Stability indicator, which is on when the weight change is within the stability range; If the stability range F1.3 is set to **0**, the indicator remains on.
- **NET:** Net weight indicator, this indicator is on when the current display is net weight.
- **COM:** Communication indicator, which flashes when data communication is in progress at a frequency of 1 second.
- **SP:** When the comparator has an output. The SP indicator is on, and the digital tube at the lower left corner, which is the serial number display, also indicates the current comparator x ($x=1... 6$) Status. Indicated by segments of the digital tube.

 : The serial number corresponds to the comparator. As shown in the figure on the right,



 As shown in the left figure, segments **1** and **3** light up, indicating the current output of comparator **1** and comparator **3**

- **HOLD:** When the function is triggered, the HOLD light on the main interface.
- **●:** USB flash drive indicator, which lights up when a USB flash drive is detected inserted.
- Auxiliary display: 1) In the weighing mode: Long press the key  on the main interface to set the auxiliary display content. You can set analog output

(A.O.), tare weight value (TARE), sensor voltage (L mV), date (Date), and time (TIME).

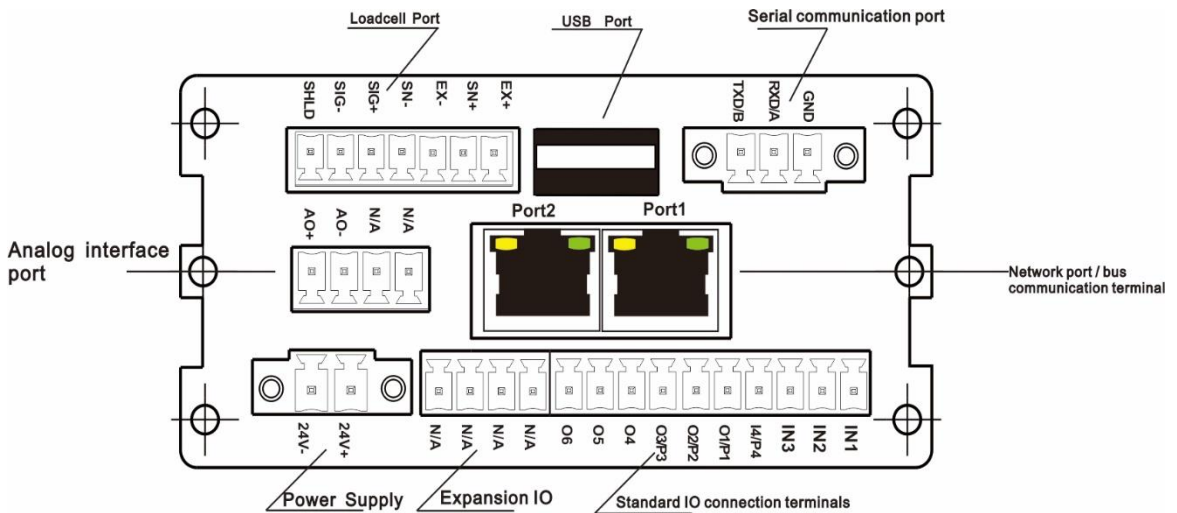

2) In the force measurement mode: Long press the key  on the main interface to set the auxiliary display content. You can set hold result (Hold), date (Date), time (TIME), tare weight (TARE), analog output (A.O.), and loadcell voltage (L mV).





2.2 Back-panel Instruction





2.3 Key Instruction

The **G-2301P** has 6 key functions, and there is a distinction between short press and long press. The key diagram is as shown below:

Keys	Operation interface	Short press	Long press
	Main interface	Print	Print feed paper
	Menu interface	Switch to the previous sub-option	/
	Number input	Number or letter +1	/
	Option class	Switch to the previous sub-option	/
	Main interface	Tare (Weigh Mode) Maintain Function (Force Mode) <small>Note 1</small>	Set the preset tare
	Menu interface	Switch to the next sub-option	/
	Number input	Number or letter -1	/
	Option class	Switch to the next sub-option	/
	Main	Zero by Key	Enter the zero calibration

	interface		interface (CAL Zr)
	Menu Interface	/	/
	Number input	Move the number position to the left	/
	Option class	/	/
	Main Interface	Enter Calibration parameters (C)	Go to the Time Settings menu, see the Time Settings Menu instruction for details ^{Note 2}
	Menu interface	Switch to the next main option	/
	Number input	Move the number bit to the right	/
	Option class	/	/
	Main Interface	Go to Menu (F)	Quickly view the software version, compilation date, 138 code, and serial number
	Menu interface	Confirm selection	/
	Number input	Confirm the selection	/
	Option class	Confirm selection	/
	Main interface	Tare and return the gross weight	Set the auxiliary display content to set the analog output (A.O.), TARE weight value (TARE), loadcell voltage (L mV), Date(Date), TIME (TIME) ^{Note 3}
	Menu interface	Go back to the previous level	/
	Number input	Go back to the previous level	/
	Option Class	Return to the previous level	/

Note 1: In the force measurement mode, the key function  is changed to the hold function. A short press  activates the hold mode. On the weight display interface, this input is effective once to start the hold state, and it stops the hold state when it is pressed again. When the hold function is triggered: the HOLD light on the main interface will be on.

Note 2: Time menu

Number	Initial value	Parameter and Instruction
H1.1	-8.0	Time zone setting, range: -12.0 zone to +12.0 zone. Set the interval to 0.5 time zone Note that the time and date will change after the time zone is modified;

		The position of the symbol can only be selected as "-" or space by pressing the up and down keys.
H1.2	YY.MM.DD	Date display format, optional: YY.MM.DD ; DD.MM.YY .
H1.3	2025.09.03	Set the date, modify a bit press the MENU key, the current bit flashes in the modification state, and you can modify the value with the up and down keys. The display format is set by H1.2 . The YY (year) parameter range is 00-99, the MM (month) parameter range is 00-12, and the DD (day) parameter range is 00-31
H1.4	06.03.06	Set time, modify a bit press the MENU key, the current bit flashes in the modification state, and you can modify the value with the up and down keys. HH (hours) parameter range 00-23, MM (minutes) parameter range 00-59, SS (seconds) parameter range 00-59.

Note 3: Information View interface instruction

Press the MENU key to switch the display of version date, 138 code, and serial number.

Version Date: The main display shows the version number, the secondary display shows the version date, and the status indicator shows the add-on board configuration (as described in the sheet below);

At this interface, the status indicator is on, as shown below:

SP 1	Optional AD5422 analog add-on board installation
SP 2	Reserve
SP 3	Reserve
ZERO	Optional 4-way output add-on board
STAB	Optional standard network port board
NET	Optional bus network port add-on board

138 code: Keep pressing the MENU key to display the 12-bit 138 code;

Serial number: Press the **MENU** key again to display the **13-digit** serial number. The main display shows the first 6 digits of the serial number, the serial number bit shows the 7th digit, and the secondary display shows the last 6 digits of the serial number.

Chapter 3 Installation and Wiring

3.1 Controller Power wiring

The **G-2301P** controller uses a 24V power supply. The wiring of the power terminals is as shown in the following figure:

NOTE: THIS PRODUCT IS POWERED BY A 24V DC POWER SUPPLY. USING A 220V AC POWER SUPPLY WILL PERMANENTLY DAMAGE THE INSTRUMENT.

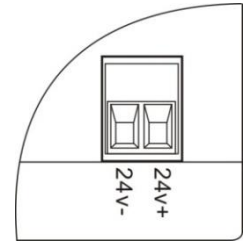

3.2 Loadcell Connection

The **G-2301P** controller **requires an external resistance strain bridge load cell, and the connection terminals are assigned to each port as:**

Ports	EX+	SN+	EX-	SN-	SIG+	SIG-	SHL
Six-wire system	Power positive	Sensitive positive	Power negative	Sensitive negative	Signal Positive	Signal negative	Shielded wire

✘ When connecting a four-wire loadcell, the **EX+** and **SN+** ports and the **EX-** and **SN-** ports **must be short-circuited**. Otherwise, the instrument weight data will not be read properly.

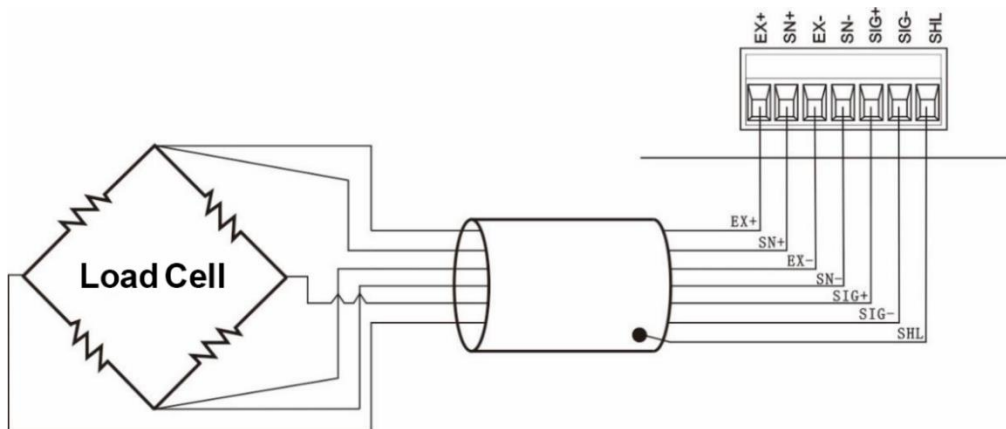

Notes:

1. Since the loadcell output signal is an analog signal that is sensitive to electronic noise, the loadcell wiring should use shielded cables and be laid separately from other cables, especially away from AC power sources;
2. Four-wire loadcells can be chosen for short transmission distances with little temperature variation or for low precision requirements; But six-wire loadcells should be chosen for applications with long transmission distances or high precision requirements;
3. For applications where multiple loadcells are connected in parallel, ensure that

the sensitivity (mV/V) of each load cell is consistent.

3.3 IO interface connection

The standard IO of the **G-2301P** controller is **4** inputs and **6** outputs. An optional **4** output channels can be selected to meet the requirement of **4** inputs and **10** outputs (the optional 4 output channels need to be declared).

The input and output interfaces are valid at a low level. The standard **IO** uses transistor output, with a drive current of **200mA** per channel.

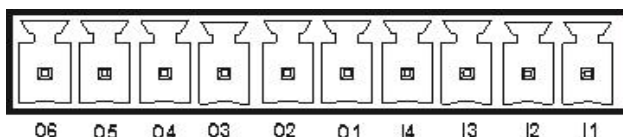

IO wiring instruction:

Connect the instrument to external devices via wiring, and control the instrument with external inputs for functions such as zeroing, taring, and printing. Display the current status of the instrument through the output, such as zero point, stability, or a comparator output, etc.

The use of the IO is illustrated as follows:

Input interface connection: Connect the terminals of the external control device one-to-one to the input terminals of the controller and test through the **F8.1** IO port. For specific operations, refer to the [6.8.1 IO testing section](#). Test the connection status. If the connection is successful, enter the F6.1 **input port** configuration, set the function definition and debounce time parameters for each input port. For example, set input port 1 to zero. At this time, press the corresponding external device connection port key, and the instrument will perform the zero operation (within the zero range). Other input functions are operated in the same way. See [Section 6.6.2](#) for specific IO definition operations.

Output interface connection: Connect the external indicator device terminal one-to-one to the controller's output terminal and test through the **F8.1** IO port. For specific operations, refer to the [6.8.1 IO test section](#). Test the connection status. If the connection is successful, enter the F6.2 **output port configuration** and set the functional parameters of each output port. For example, set output port 1 to stable. At this time, the instrument weight is in a stable state and the indicator light corresponding to the external output port is on, and the instrument output stable is valid. Do the same for the functions of other output ports.

Instrument input interface schematic diagram:

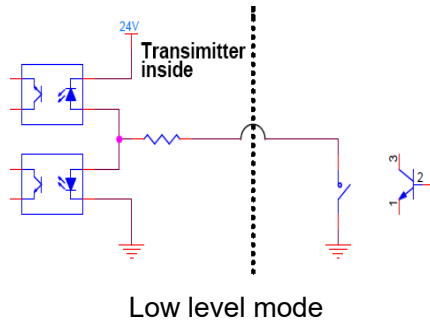

Instrument output interface schematic diagram:

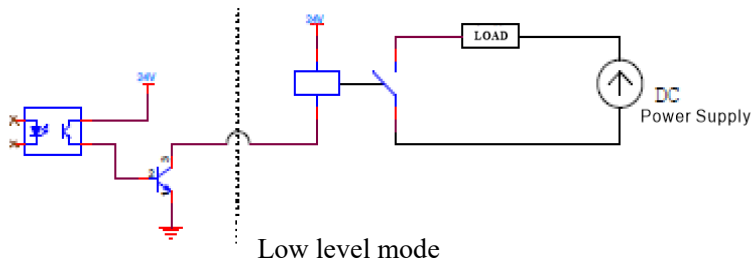

By default, the factory has no function. can customize the IO definition function via **F6**. See [Section 6.6](#) for details.

When the switch quantity is selected as relay output (5A): The interface diagram is as follows:

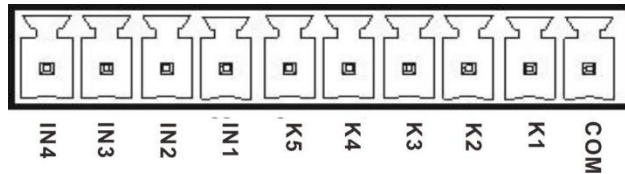

3.4 Serial Connection

The G-2301P instrument offers RS232 and RS485 optional functions, allowing users to choose their own output mode.

3.4.1 Serial port RS485/RS232 output

If the instrument is equipped with **RS485** communication mode, it will have **485** serial port communication function. If **RS232** is selected, it will have **232** serial communication function. Serial communication parameters are shown in [Section 6.2](#). The serial port terminals are connected as follows:

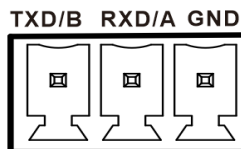

RS485 wiring method:

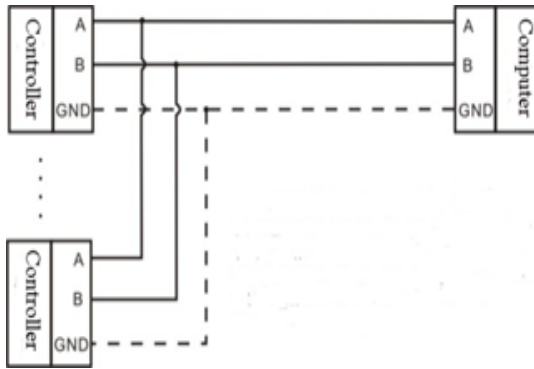

In **RS485** mode, **GND** is the signal ground. In situations where interference is severe, low-resistance wires are used to connect the signal ground to make the ground potential of each node equal, which can significantly improve communication quality.

RS232 connection method:

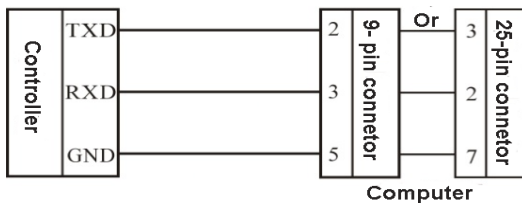

※ **GND** must be connected in **RS232** mode.

3.4.2 Troubleshooting Serial Port

If the serial port fails to communicate, please check:

- Check the wiring as described above to ensure it is correct.

The **RS232** interface must be connected to all three lines, **Rx, Tx, GND**.

The **RS485** interface must be connected to wires **A** and **B**.

Make sure that the parameters of the connection port are consistent with those of the host computer.

The machine number, baud rate, data format and communication protocol must be consistent with those of the host computer and PLC.

3.5 Network port connection

The **G-2301P** product supports single network port, dual network port communication and PN bus communication (optional function, please specify when ordering). For specific network port communication parameters, see the list of [network port](#) parameters in [Section 6.3 F3](#).

- 1) Single Network port Optional, support the **Modbus, RDP, TT, RE, SP1, EASY** protocol, such as **LAN1** so communication can, **LAN2** temporarily not enabled.
- 2) Optional dual network port function, with built-in switches at the network port for **EASY** cascading, also supports **Modbus, RDP, TT, RE, SP1, EASY** protocols.
- 3) When communicating through PN, which can connect to any of the instrument's network ports for communication.

3.5.1 Troubleshooting of network ports

If the network port fails to communicate, please check:

- Check the port indicator.

The hardware connection is normal, and the communication indicator inside the instrument remains on.

The network cable is properly connected and the connection indicator is flashing.

- Check if the communication protocol is consistent with the host computer and PLC.

○ Confirm that the G-2301P can be pinged by the network. If not, check the hardware interface section.

- Check if there is any IP conflict.
- Restart the instrument.

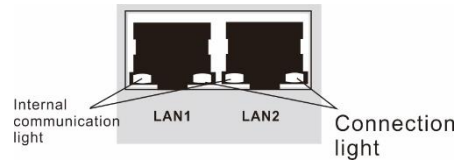

3.6 Analog Connection

The **G-2301P** has **1** analog output function. Interface **AO+** (positive), **AO-** (negative). The analog is an optional function and needs to be declared when ordering.

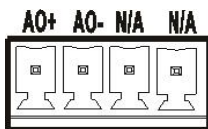

The analog output is divided into **voltage output type** and **current output type**. The user can select the corresponding mode in the output mode of the F4 analog parameter.

[For analog mode](#), see [Section 6.4 F4 Analog Parameter list](#). [For analog calibration](#), see [Section 5.2](#).

Chapter 4 Menu Overview

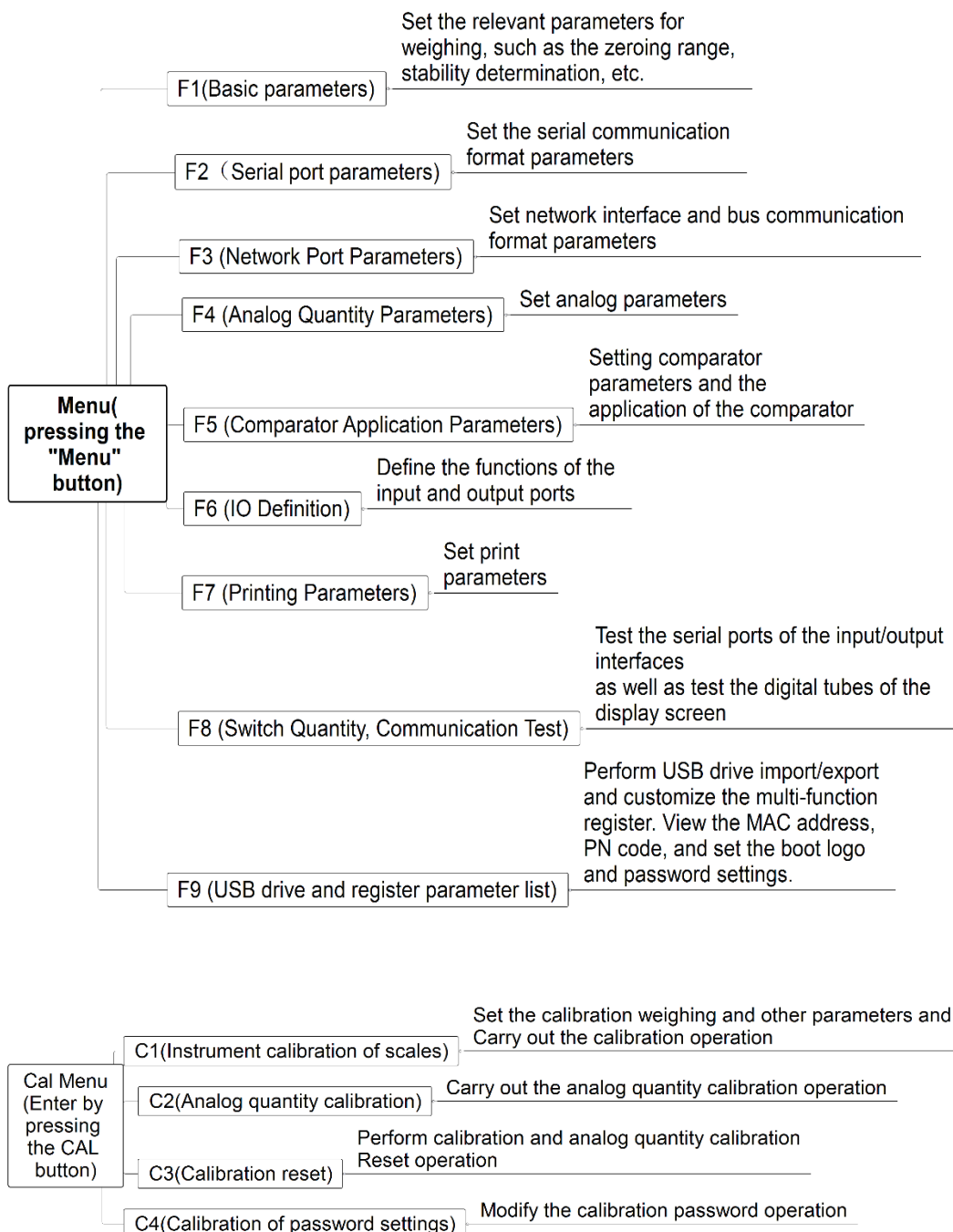

Chapter 5 Weight Parameters

The indicator should be calibrated when using the **G-2301P** weight transmitter for the first time, or when any part of the weighing system changes, or when the current device calibration parameters do not meet the user's requirements. Calibration can determine the zero point, gain point, etc. of the weighing system.

5.1 C1 Weight parameter

Number	Parameter Name	Initial value	Note
C1.1 Enable operation			
C1.1.1	Remote calibration enabled	OFF	ON, OFF is optional. When set to OFF , remote calibration is not allowed.
C1.1.2	Theoretical value enabled	OFF	ON, OFF is optional. When set to OFF , do not calculate the weight using the theoretical value.
C1.2 Weight parameter settings			
C1.2.1	Unit	kg	Range: t; kg; g; lb;
C1.2.2	Range	10000	The maximum displayed value of the instrument is usually taken from the loadcell range. Range: 1 to 999999. Display follows the actual decimal point display of C1.2.3 .
C1.2.3	Division	1	The instrument indicates the minimum variation of the value. The left and right keys select the decimal point position, and the up and down keys select the division range as follows: 50, 20, 10, 5, 2, 1, 0.1, 0.2, 0.5, 0.01, 0.02, 0.05, 0.001, 0.002, 0.005, 0.010, 0.020, 0.050, 0.0001, 0.0002, 0.0005, 0.00001, 0.00002, 0.00005
C1.3 Zero calibration			
C1.3.1	Auto zero calibration	//	After emptying the weighing platform, press the Menu key to display "Wait" when unstable, and display "OK" when stable. Use the current obtained voltage value status as the zero voltage to complete the zero calibration.
C1.3.2	Voltage zero calibration	//	Manually input the voltage with 4 decimal point as the zero point voltage
C1.4 Weight calibration (parameters visible when C1.1.2 is set to OFF)			
C1.4.1	Weight calibration point 1	//	Calibrate weight point, supporting 5-point calibration. When the previous point is calibrated, the other weight points will be reset to the uncalibrated state (default value: 10.0000mV, 10000kg). If calibration point 1 is performed, calibration points 2-5 will be reset to 0 . See 5.1.2
C1.4.2	Weight calibration point 2		
C1.4.3	Weight calibration point 3		
C1.4.4	Weight calibration point 4		
C1.4.5	Weight		

	calibration point 5		Weight Calibration for specific operations.
C1.5 Theoretical calibration (parameters visible when C1.1.2 is set to ON)			
C1.5.1	Loadcell sensitivity	2.000 0	loadcell true sensitivity, 4 decimal point, and average sensitivity if multiple loadcells.
C1.5.2	Total loadcell capacity	10000	The true loadcell range, if multiple loadcells, is the sum of all loadcell capacities.
C1.6 Weight correction			
C1.6.1	Auto correction	1.000 00	When the instrument enters "C1.6.1", it records the current weight. Then the user needs to add or remove the weight in this interface, enter the weight of the removed weight, press the menu key to confirm, and the instrument will wait until it stabilizes to automatically calculate the correction factor.
C1.6.2	Manual calculate correction	1.000 00	After calibration, if the zero point is correct, there is a weight deviation that can be used to correct the weight value. The value is calculated as follows: If the instrument shows weight A but the weight after weighing is B , the correction factor is calculated as:(actual weight B * current correction factor)/ displayed weight A



5.1.1 Zero calibration

Zero point calibration is the zero position calibration of the weighing platform.

There are two ways to perform zero calibration: automatic zero calibration and voltage zero calibration. Zero calibration must be performed in the "automatic" mode when new equipment or weighing structures are adjusted.

Automatic zero calibration

Calibration success condition: Scale platform stability.

Operation: Enter the **C1.3** zero point calibration interface, press the key  to enter the auto zero point calibration instrument interface, and display the current millivolt. After empty the weighing platform, wait for it to stabilize. When the STAB indicator is on, press the key . After successfully entering the calibration

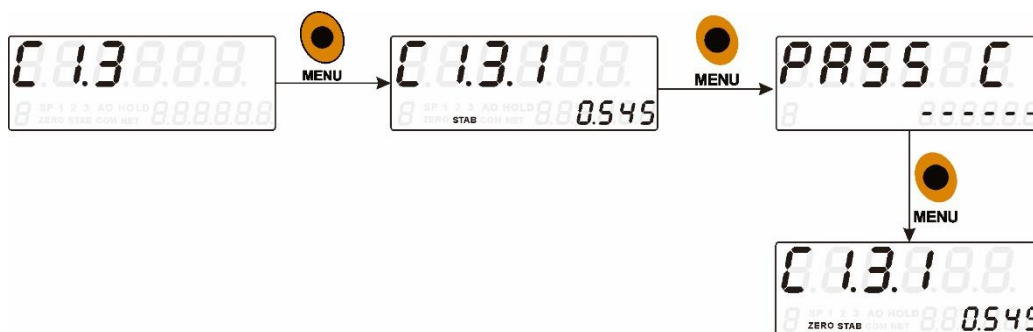

password, press the key  again. Then the interface Zero indicator is on, and the automatic zero calibration is completed.

Voltage zero calibration:

Manually enter the millivolt corresponding to the zero point, calibrate zero point by the input value. Press the key  again, and after displaying "OK" for 3 seconds, the voltage zero calibration is completed.

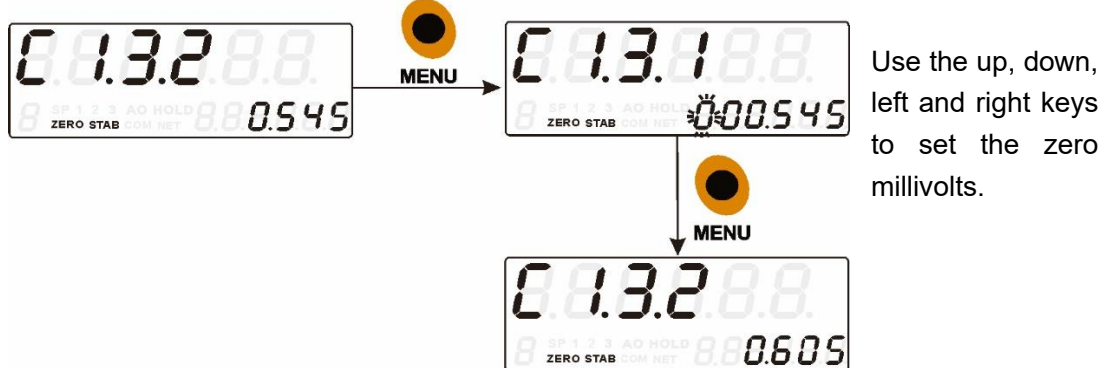

※ Generally used in calibration without weight, record the value when calibration with weight is used for manual input.

5.1.2 Weight calibration

Weight calibration is the use of standard weights for weight calibration. The instrument supports **5-point** calibration, providing users with the maximum number of calibration points as needed.

Calibration method: (Zero calibration is required before gain calibration)

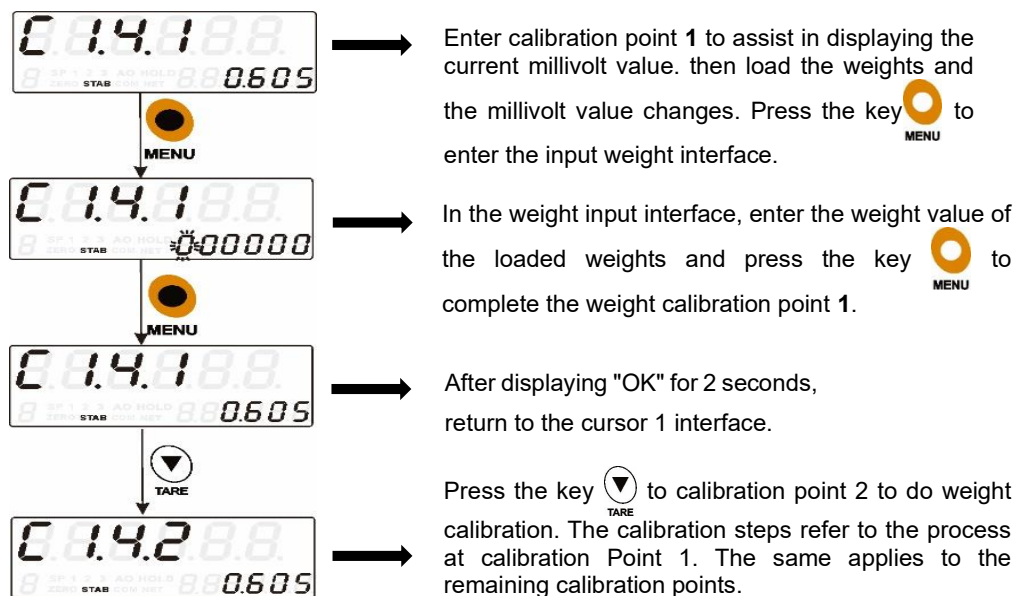

Note when using multi-point calibration:

- 1) Users can choose the number of calibration points. For single-point calibration, exit after the first weight point is calibrated.
- 2) Do not calibrate across points, otherwise an "**Err20**(the previous point was not calibrated during weight calibration)" alert will appear. When using three-point calibration, calibration points **1**, **2**, and **3** must be carried out instead of crossing point **2** to calibrate points 3 and 4 after completing point **1**.
- 3) For multi-point calibration, the weights need to be incremented. For example, the weight of the weights at calibration point **2** must be greater than that of the weights at calibration point **1**; otherwise, the alarm prompt "**Err16** voltage during weight calibration is less than or equal to zero point or the previous calibration point" will appear.

5.1.3 Theoretical calibration

Theoretical calibration is the operation of weight calibration by inputting the sensitivity of the connected loadcell and the range value of the loadcell.

Parameters are visible when the C1.1.2 theoretical value enable switch is set to ON. Theoretical value calibration takes effect only after the loadcell sensitivity and total range are set.

Theoretical value calibration requires two steps:

- 1) Set the loadcell sensitivity in **C1.5.1 (if multiple loadcells are connected, input the average sensitivity)**
- 2) Set the total loadcell capacity in **C1.5.2 (if multiple loadcells are connected, input the total loadcell range)**

5.2 C2 Analog calibration parameters

Number	Parameter Name	Initial value	Note
C2.1	Analog calibration point 1	1.000 mA / 1.000 V	Current range : 0 to 24.000mA , voltage range : 0 to 10.0000V
C2.2	Analog calibration point 2	4.000 mA / 3.000 V	Current range : 0 to 24.000mA , voltage range : 0 to 10.0000V
C2.3	Analog calibration point 3	12.000 mA / 5.000 V	Current range : 0 to 24.000mA , voltage range : 0 to 10.0000V
C2.4	Analog calibration point 4	20.000 mA / 7.000 V	Current range : 0 to 24.000mA , voltage range : 0 to 10.0000V
C2.5	Analog calibration point 5	22.000 mA / 9.000 V	Current range : 0 to 24.000mA , voltage range : 0 to 10.0000V

5.2.1 Analog calibration operation





Analog output mode **F4.1** Select current/voltage mode. In the normal display state, the current displayed voltage/current value can be seen in the auxiliary display bar.

The analog output of the instrument has been calibrated at the factory, and users do not need to perform calibration again. If the analog output of the instrument is

abnormal, the user may calibrate analog by themselves. Current calibration is done in the same way as voltage calibration. current calibration is used as an example (it is recommended to calibrate under the guidance of a professional) :

Analog current calibration can be done by adjusting the current value. Tools: A multimeter capable of measuring current.

Take current point 1 as an example, here's how:

- i. Set the multimeter to the mA range and connect the **AO+** (positive) and AO- (negative) terminals of the instrument;
- ii. Enter the C2.1 calibration point 1 interface. then view the current measurement value of the multimeter. Then press the key  to modify the current output value, which is consistent with the measurement value of the multimeter. Press the key  to confirm to complete the calibration of analog calibration point 1.
- iii. Go to C2.2 Point 2, which is also to view the multimeter's current measurement. Then press the key  to modify the current output value, which is consistent with the multimeter's measurement, and press the key  to confirm to complete the calibration of analog point 2. The rest calibration points follows the same steps.
- iv. Current calibration supports **5-point** calibration. The customer adjusts the calibration as needed.

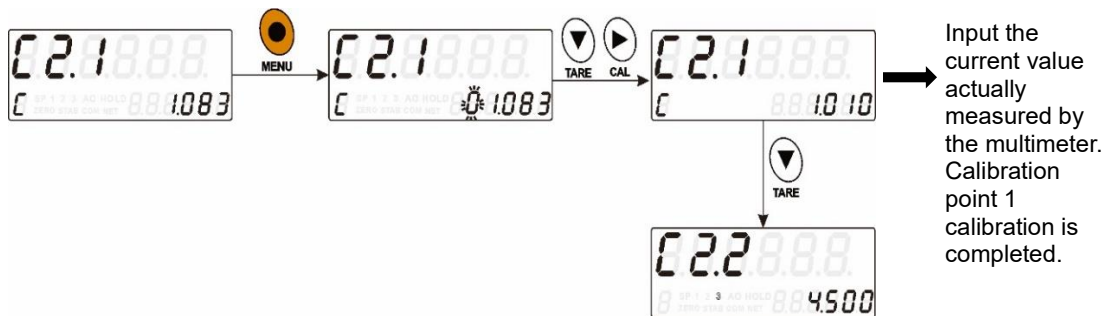

5.3 C3 calibrate reset parameters

Num ber	Parameter Name	Instruction
C3.1	Weight calibration reset	Reset the weight parameter C1 to the factory default. Operation: Enter C3.1, the auxiliary display "WT", press the MENU key to activate, "WT" flashes, then press the MENU key again to perform the reset operation.
C3.2	IO calibration reset	Reset the analog calibration parameter C2 to the factory default. Operation: Enter C3.2, the auxiliary display "dA", press the MENU key to activate, "dA" flashes, then press the MENU key again to perform the reset operation.
C3.3	All calibration reset	Reset all calibration parameters, C1+C2 , factory default. Operation: Enter C3.3, the auxiliary display "ALL", press the MENU key to activate, "ALL" flashes, then press the MENU key again to perform the reset operation.

5.4 C4 calibrate the password

This is used to set the calibration password. Do it as follows:



Use the up, down, left and right keys to adjust the value and enter the new password for the first time.

Enter the new password for the second time and make sure it is the same as the first password.

The password has been modified successfully. Enter the new password for calibration.

Chapter 6 Parameter List

6.1 F1 Basic Parameter list

Number	Parameter Name	Initial value	Note
F1.1 zero operation			
F. 1.1	Power-on zero	0	Range: 0 to 99 (* full scale %); When set to 0 , the power-on auto-zero function is turned off.
F1.1.2	Zero point power-off save	OFF	ON,OFF is optional. Each zeroing ON saves floating zeros
F1.1.3	Zero range	20%	Range: 0 to 99 (* full-scale %). Zeroing is prohibited when the value is 0
F1.1.4	Zero range	1d	Range 0-99d . Turn off zero tracking when the parameter is 0 . When the parameter is not zero, the system will automatically track zero position if the weight change is less than the zero range during the zero tracking time.
F1.1.5	Zero time	1000ms	Range 1-5000ms . The system will automatically track zero if the weight change is less than the zero range during the zero tracking time.
F1.2 Tare weight operation(When the force mode is selected, the parameters will not be visible.)			
F1.2.1	Tare weight operation switch	OFF	Range: ON,OFF ; When set to OFF, F1.2.2 to F1.2.7 parameters are hidden.
F1.2.2	Tare weight memory function	OFF	Range: ON,OFF ; When set to ON ,turn on the tare memory function.
F1.2.3	Negative net return to zero	OFF	Range: ON,OFF ; When set to ON and the preset tare weight is set to 0 , if the net weight is negative, the net weight will automatically return to zero.
F1.2.4	Auto tare switch	OFF	Range: ON,OFF ; When the auto tare set to ON , the preset tare weight is invalid. When the gross weight exceeds the auto tare threshold and reaches a stable state, the auto tare is activated and the net weight is displayed. If it does not exceed the auto tare threshold, manual tare is required. Automatic continuous taring is performed only once in the gross weight state, and it can be performed again after automatic taring or after taring
F1.2.5	Automatic	0	The automatic taring switch is ON . In the

	taring threshold		gross weight state, when the gross weight exceeds the automatic taring threshold, it will automatically tare.
F1.2.6	Auto remove tare switch	OFF	Range: ON,OFF ; When set to ON , when the gross weight is less than the automatic tare threshold and a stable state is reached, the tare is automatically cleared and the gross weight display state is entered (the purpose of judging stable is to prevent the tare weight from being automatically cleared near the threshold).
F1.2.7	Auto remove tare threshold	0	In net weight mode, if the gross weight is below the threshold, the tare will be automatically removed
F1.3 Stable parameters			
F1.3.1	Stable range	1d	Range: 0-99D . When the parameter is 0 , the weight stability marker is turned off and remains in effect. When the parameter is not 0 , the weight is stable if the range of weight variation does not exceed this value throughout the stable time.
F1.3.2	Stable time	1000ms	Range: 1-5000 milliseconds. Weight is stable if the range of weight variation does not exceed the stabilization range within that time
F1.4 Filter and sampling			
F1.4.1	Digital filtering	5	Range: 0-9 ; The larger the number, the higher the filtering strength, but the instrument response time will be longer.
F1.4.2	Remove Vibration filter	0d	Range 0-99d , 0 indicates the vibration suppression filter is turned off, non-zero, when the weight variation range is within the vibration suppression filter parameter range, the filter is activated and works with the digital filter to output a more stable weight indication.
F1.4.3	AD sampling speed	200	Range: 50; 60; 100; 120; 200; 240; 400; 480; 800; 960 (SPS) .
F1.4.4	Loadcell signal range	-15-15mV	Range: 0-5mV; 0-10mV; 0-15mV; -5-5mV; -10-10mV; -15-15mV . The instrument adjusts the signal acquisition range according to the input range to ensure more accurate measurement. This instrument uses a 5V bridge, a 1mV/V loadcell, and the signal range is 0 to 5mV , and so on.
F1.5 reset			
F1.5	Basic Parameter reset	//	Perform a factory zero operation on the basic parameters

6.1.1 Zero operation

Zeroing success conditions:

- 1) Weighing platform stable; 2) The weight is within the zeroing range.

achieve zeroing operation:

- 1) Key zeroing; 2) Zeroing the input port is valid; 3) Communication port zeroing (remote zeroing switch on)

6.1.2 Tare weight function

Tare weight operation switch:

Turn on/off tare functions such as port tare and clear tare; Set this parameter to ON to perform tare settings.

Tare weight memory function:

Enable/Disable the tare weight memory function. If ON, the instrument retains the previous tare weight after power-off and restart.

Preset tare weight:

You can set the tare weight by long pressing key  on the main interface. If this value is not 0, you will use this tare weight for taring.

※ Note: The instrument is powered on and in gross weight mode. When tare removed, the instrument records tare weight and enters net weight mode.①

②The instrument cannot zero in the net weight display mode.

③Power-on zeroing does not work when tare weight memory and power-on zeroing are turned on simultaneously.

6.2 F2 Serial Port Parameter list

Number	Parameter Name	Initial value	Note
F2.1	Slaver number	01	Range: 01-99
F2.2	Data format	8-E-1	Range: 8-N-1, 8-E-1, 8-O-1, 7-E-1, 7-O-1 (Note: Only 8-bit data bits are supported in modbus protocol)
F2.3	Baud rate	38400	Range: 1200,2400,4800,9600,19200,38400,57600,115200
F2.4	Communication Protocol	Modbus RTU	Range: Modbus RTU, Modbus ASCII, CS.RDP protocol, CS.tt protocol, CS.rE, CS.SP1 protocol, CS.EASY, Print, NONE
F2.5	Continuous sending interval	20ms	Parameters are visible when tt sends the protocol. It is the time interval between frames. Range 0-1000ms
F2.6	Two-byte	AB-CD	Range: AB-CD (high byte first), CD-AB (low

	mode		byte first)
F2.7	TT Protocol checksum switch	OFF	Parameters are visible when tt sends the protocol. OFF: Do not send the check ON: Send the check(Note: (When the force mode is selected, the parameters are not visible))
F2.8	Communication indicator	USART	USART: The COM indicator on the current display panel indicates the serial port NET: The COM indicator on the current display panel indicates the network port
F2.9	Serial port parameter reset	//	

6.3 F3 Network port Parameter list

Number	Network port parameters	Initial value	Note
F3.1	Instrument IP	192.168	IP high segment. Range : 0.0 to 255.255
F3.2	Instrument IP	0.1	IP low segment. Range : 0.0 to 255.255
F3.3	Subnet Mask	255.255	Subnet mask high segment. Range : 0.0 to 255.255
F3.4	Subnet Mask	255.0	Subnet mask low segment. Range : 0.0 to 255.255
F3.5	Connect 1 network port parameter		
F3.5.1	Connect to port 1	502	Range: 1-65535 0 indicates closing the connection
F3.5.2	Connect 1 Communication Protocol	Modbus	When choosing a regular network port, the protocols are: Modbus,RDP,TT,RE,SP1,EASY.
F3.5.3	Two-word mode	AB-CD	Range: AB-CD (high word first), CD-AB (low word first), parameters visible when Modbus/TCP protocol is selected.
F3.5.4	Connect 1 continuously send intervals	20ms	Parameters are invisible when Modbus/TCP protocol is selected and are used to control the time intervals between frames. Range: 10-6000ms.
F3.6 ~ F3.8	Connect ports 2 to 4 parameters. The port number is set to 0 by default. For other parameters, refer to F3.5 for connect port 1 network parameters.		
F3.9	Port TT protocol checksum switch	OFF	Range: OFF, ON OFF: Do not send verification; ON : Send the check.
F3.10	Bus write switch	OFF	Range: OFF, ON ON : During PN communication, the instrument parameters are controlled by "Module parameters" in the master station configuration. When the instrument is

			powered on, the master station automatically writes the parameters set in "Module Parameters" to the instrument. OFF: In PN communication, the instrument parameters are not controlled by the master station 'module parameters'.
F3.11	Bus data types	Int	Selection of PLC display type. Range: Int(integer), ON(floating-point)
F3.12	Network port parameter reset	//	Display "TCP", press the MENU key TCP flashes, then press the MENU key again to perform the reset operation.

6.4 F4 Analog parameter list

The following parameters will only be visible if an analog expansion board is selected.

Number	Parameter Name	Initial value	Note
F4.1	Analog output mode	4-20mA	Range: 4-20mA, 0-10V, -10V-10V, User_I, User_U (When set to User_I or User_U , the following parameters are only visible from F4.2 to F4.7)
F4.2	Customize mini output	0mA/0V	Minimum output corresponding to the analog Range: 0mA to 24mA/-10V to 10V.
F4.3	Custom zero output	4mA/0V	Zero output corresponding to the analog. Range: 0mA to 24mA/-10V to 10V.
F4.4	Custom full-scale output	20mA/0V	The analog corresponds to full-scale output. Range: 0mA to 24mA/-10V to 10V.
F4.5	Customize max output	24mA/0V	Maximum output of analog. Range: 0mA to 24mA/-10V to 10V.
F4.6	Analog associated weight setting	Disp	Disp(Displayed weight), Gross(gross weight), Net(net weight)
F4.7	Analog parameter reset	//	Display "AO", press the MENU key AO to flash, then press the MENU key again to perform the reset.

6.5 F5 Comparator parameter list

The **G-2301P** offers six comparators with parameter values such as comparison mode, comparison conditions, valid time, and invalid time. It should be used in conjunction with the switch I/O. For specific parameter Settings and usage, please refer to the following instructions.

Number	Parameter Name	Initial value	Note
F5.1	Comparator 1 parameter		
F5.1.1	Comparison mode	OFF	Optional: 0. OFF, 1. CV1 or less (less than or equal to), (2) or greater CV1 (greater than or equal to), (3) C1, C2 (between), 4 - C1. C2 - (between).

			When set to OFF, parameters F5.1.2 to F.1.7 are not visible.
F5.1.2	Comparison value 1	0	Higher priority comparison value, comparison value 1 is used by default when there is only one comparison parameter, comparison value 2 is invisible. Range: -999999-999999 . When negative, the most significant bit can be switched to a minus sign -.
F5.1.3	Comparison values 2	0	When using two comparison value, this value must be greater than the first comparison value. Range: -999999-999999 . When negative, the most significant bit can be switched to a minus sign -.
F5.1.4	Achieve Mode	Delay	When the comparison is successful, the instrument outputs effective additional constraints. Optional: Delay (Output Delay): Outputs after the successful time exceeds the determination time; Stab-D (Output after Weight Stabilization): Starts delaying immediately when the comparison conditions are met and stable; outputs are valid upon the end of the delay, and the stability flag is no longer judged during the delay period.
F5.1.5	Achieve judgment time	1000ms	The minimum judgment time for success. Range: 0 to 50000 ms .
F5.1.6	Failure mode	Delay	Optional: Delay (Output Delay): Output is generated after the successful time exceeds the failure determination time; Stab-D (Output after Weight Stabilization): When the comparison condition is met and stabilization occurs, the delay starts immediately. The output becomes valid upon the end of the delay, and the stabilization flag will no longer be checked during the delay period.
F5.1.7	Failure determination time	1000ms	Minimum judge time for failure. Range: 0 to 50,000 ms .
F5.2 ~ F5.6	Comparator 2 to comparator 6 parameters refer to the parameter description for comparator 1 in F5.1.1 to F5.1.7 .		
F5.7	Comparator parameter reset	//	Display "SPOINT", press the MENU key SPOINT flashes, and press the MENU key again to perform the reset

6.5.1 Application Examples

Example 1: Output 1 is valid when the weight is greater than or equal to 500g and is stable; output 1 is invalid if the condition is not met and is stable.

Setting: 1) Output port 1 is defined as: **COMP1**(comparator 1).

- 2) The comparison mode is set to: $\geq CV1$ (greater than or equal to).
- 3) Set the comparison value **1** to: **500**.
- 4) Set comparison value **2** to: **0** (single-point comparison, this parameter is meaningless).
- 5) The achievement mode is set to: Stab-D (Output after weight stabilization).
- 6) Achievement determination time: **0** (non-delay mode, this parameter is meaningless).
- 7) The failure mode is set to: Stab-D (Output after weight stabilization)
- 8) Failure determination time: **0** (Non-delay mode, this parameter is meaningless)

✘ If the stable state remains invalid after weight is greater than or equal to **500g**, **output 1** will not switch to the valid state.

Example 2: If the weight is not between **200g** and **500g**, output 4 is valid after a delay of **5ms**. **If the condition is not met**, output 4 is invalid after a delay of **5ms**.
Settings: 1) Output port **4** is defined as: **COMP1**(comparator **1**).

- 2) The comparison mode is set to: -C1.C2-(**not** between).
- 3) Set the comparison value **1** to: **200**.
- 4) Set Comparison value **2** to: **500** (the set value should be greater than comparison value 1).
- 5) The achievement mode is set to: Delay (delay output).
- 6) Achievement determination time: **5ms**.
- 7) The failure mode is set to: Delay (delay output)
- 8) Failure determination time: **5ms**.

Example 3: If the input is set to enable the comparison point function and the weight is between **200g** and **300g**, the immediate output is valid; if the condition is not met, the immediate output is invalid.

Settings:

- 1) The input port **IN1** is defined as: Enable comparison point.
- 2) Switch output port **OUT4** is set to: **COMP.Go**(enable comparison point).
- 3) Set the comparison mode to: **C1--C2**(between).
- 4) Set the comparison value **1** to: **200**.
- 5) Set Comparison value **2** to: **300** (the set value should be greater than comparison value 1).
- 6) Set the achievement mode to: Delay (delay output).
- 7) **The** achievement determination time is: **0ms** (non-delay mode, this parameter is meaningless).
- 8) Set the failure mode to: Delay (delay output).
- 9) **The** failure determination time is: **0ms** (non-delay mode, this parameter is meaningless).

If the weight is between **200 and 300g**, even if the comparison condition is met, the comparator will not immediately output valid until the enabled comparison point input is valid; If the conditions are not met, the output will be immediately invalid.

6.6 F6 IO parameter list

The G-2301P controller has 4 inputs and 6 outputs as standard, and 4 outputs as optional (order declaration required, not enabled at present). When 4 outputs are selected, parameters F6.2.6 to F6.2.10 are visible. The standard IO uses transistor output, with a drive current of 200mA per channel

Number	Parameter Name	Initial value	Note
F6.1	Input port configuration parameters		
F6.1.1	Input Port 1 Function definition	None	None, Zero, CAL-Zr (calibrate zero), Tare (tare), C-Tare (clear tare), Net (switch gross/net weight), COMP.Go (enable comparison point), Print (print), P.EptIn (print feed paper), Key-L (keyboard lock), CAL-L (Calibrate lock). When selecting the force mode, you can also choose Lv_H (Level Hold) and Tirg_H (Trigger Hold).
F6.1.2	Input Port 1 debouncing time	5ms	Avoid misjudgment caused by signal jitter. Range :0-1000ms
F6.1.3	Input Port 2 Function definition	None	Refer to the function definition description of Input Port 1 F6.1.1 .
F6.1.4	Input port 2 debouncing time	5ms	Avoid misjudgment caused by signal jitter. Range : 0-1000ms
F6.1.5	Input Port 3 Function definition	None	Refer to the function definition description of Input Port 1 F6.1.1 .
F6.1.6	Input Port 3 debouncing time	5ms	Avoid misjudgment caused by signal jitter. Range :0-1000ms
F6.1.7	Input Port 4 Function definition	None	Refer to the function definition description of Input Port 1 F6.1.1 .
F6.1.8	Input port 4 debouncing time	5ms	Avoid misjudgment caused by signal jitter. Range :0-1000ms
F6.2	Output port configuration parameters		
F6.2.1	Output Port 1 function definition	None	None, Stab, Zero, OFL, Net, Print, -SIGN, Hbeat, COMP1 (comparator 1), COMP2 (comparator 2), COMP3 (comparator 3), COMP4 (comparator 4), COMP5 (comparator 5), COMP6 (comparator 6)

F6.2.2	Output Port 2 Function definition	None	Refer to the function definition description of output Port 1 F6.2.1.
F6.2.3	Output Port 3 Function definition	None	Refer to the function definition description of Input Port 1 F6.1.1.
F6.2.4	Output Port 4 Function definition	None	Refer to the function definition description of Input Port 1 F6.1.1.
F6.2.5	Output Port 5 Function definition	None	Refer to the function definition description of input port 1 F6.1.1.
F6.2.6	Output Port 6 Function definition	None	Refer to the function definition description of Input Port 1 F6.1.1.
F6.2.7	Output Port 7 Function definition	None	Optional extended IO, parameters visible. Refer to the function definition description of input Port 1 F6.1.1.
F6.2.8	Output Port 8 Function definition	None	Optional extended IO, parameters visible. Refer to the function definition description of input Port 1 F6.1.1.
F6.2.9	Output Port 9 Function definition	None	Optional extended IO, parameters visible. Refer to the function definition description of input Port 1 F6.1.1.
F6.2.10	Output Port 10 Function definition	None	Optional extended IO, parameters visible. Refer to the function definition description of input Port 1 F6.1.1.
F6.3	IO parameter reset	//	Display " IO ", press the MENU key for IO to flash, then press the MENU key again to perform the reset

6.6.1 IO Definitions

Input port Function description:

Code name	Application Function	Meaning
None	Undefined	No input
Zero	Zero	The instrument performs zeroing when the pulse signal input is valid.
CAL-Zr	Calibrate zero	The instrument performs zero calibration when the pulse signal input is valid.
Tare	Tare	The taring function is performed when the pulse signal input is valid.
C-Tare	Clean tare	In net weight mode, when the pulse signal input is valid, the cleaning tare function is performed, the removed tare weight is restored, and the main interface display back to gross weight.
Net	Gross/net weight switch	The main display switches gross/net weight when the pulse signal input is valid.
COMP.Go	Enable	Defines this function, comparing whether the point

	comparison points (Level signal)	outputs is controlled by the state of that IO port. The comparator output is valid if the comparison condition is met and the input is valid; otherwise, it is not output. If the function is not defined, there will be an output when the comparison condition is met, not controlled by that input port. See Application Example 3 of 5.5.1.
Print	Print	The print function is executed when the pulse signal input is valid. Do not respond if the current content is not fully printed.
P.EptIn	Print run paper	When the pulse signal input is valid in the non-print state, the print feed function is executed.
Key-L	Keyboard lock (Level signal)	When the signal input is valid, all keys cannot be used. The low-level signal is valid.
CAL-L	Calibration lock	Once defined, the signal is valid (level signal), and I/O, serial port network, modbus, PN cannot perform weight calibration, and an alarm Err07 is prompted. Calibration is possible on the contrary.
Tirg_H	Trigger retention	This signal is a pulse signal. When the mode is set to external trigger, this input is valid once, initiating the holding state. If it is valid again, the holding state will be terminated. (In the force measurement mode, the parameters can be selected)
Lv_H	Level maintenance	When the mode is set to external trigger, this signal is valid and triggers the hold function. When the signal is invalid, the hold is released (for level-triggered mode, other external triggers are invalid). (In force measurement mode, this parameter is optional.)

Function description of the output port

Code name	Application Function	Meaning
None	Undefined	No output
Stab	Stable	The instrument stability flag is valid when there is an output.
Zero	Zero	The instrument zero indicator light is valid when there is an output.
Net	Net weight	Output is valid when the instrument is at net weight.
Print	Printing	When the instrument outputs valid during the printing process.
-SIGN	Load weight	Output when the displayed weight is less than 0 .
Hbeat	Communication Heartbeat	1HZ square waves are emitted only when communicating via serial port.
COMP1~COMP6	Comparator 1-6	Comparator 1-6 has an output when the conditions are met; If an input port is set to enable the comparison point, the input is valid and the comparator has an output.

6.6.2 IO defines the operation

Users can define the input and output of the IO as needed. Take the definition of the input port as an example. The same operation is done for the output port. The operation is as follows:

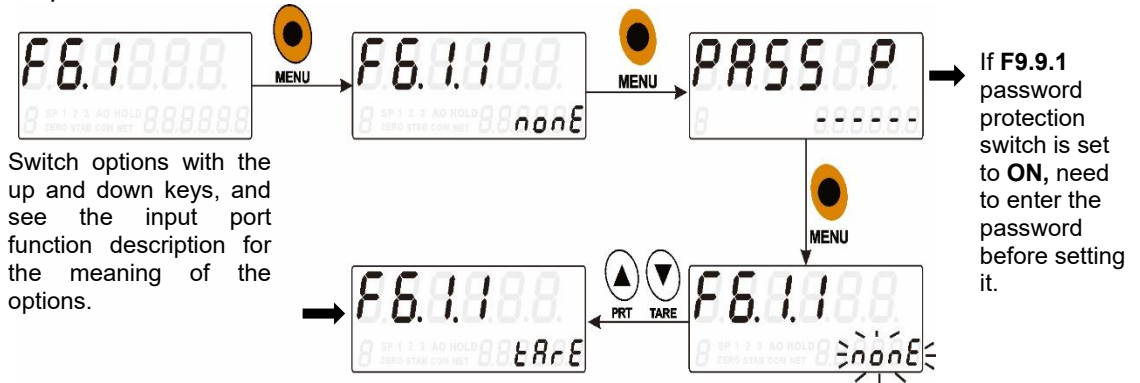

6.7 F7 Print parameter list

The F7 parameter will only be visible if the F2.4 communication protocol in the serial port parameter is set to Print.

Number	Parameter Name	Initial value	Note
F7.1	Number of header information lines	0	Select how many lines of header information to use, range 0 to 4
F7.2	Number of tail information lines	0	Select how many lines of tail information to use, range 0 to 4
F7.3	the number of feeding paper lines	2	Range 0 to 4
F7.4	Print content	All	Set the weight content for printing. Gross weight Gro.Net (gross weight + net weight) Gro.Tar (gross weight + tare weight) ALL (gross weight + net weight + tare weight)
F7.5	Time format	DAT.TIM	Print time format. NONE (none); TIM (only time) DAT (only date); DAT.TIM (Time&Date)
F7.6	Print format	16C.CHN	Set the language of the print content to a maximum width of 16 bytes. 16C.CHN (Chinese); 16C.ENG (English)

Examples of Print format



Parameter Settings		Print ticket content (Chinese)
Number of header information lines	1	------(header information line)
Number of tail information lines	1	@2025/06/09 15:19

Print feed paper	2	Gross weight: 61kg Net weight: 36kg tare weight: 25kg -----(tail information line) (Feed paper line 1) (Feed Paper Line 2) ----- (second print)
Print content	ALL(gross weight + net weight + tare weight)	
Print language	16 c.CHN (Chinese)	
Head information 1 line	-----	
Tail information line 1	-----	

6.8 F8 IO and communication test



Number	Parameter Name	Instructions
F8.1	IO test	Perform hardware tests on IO ports . See 6.8.1 IO Test Operations for details.
F8.2	Indicator digital tube test	After confirming by pressing MENU, all the tubes in the digital tube display interface remain on. Press it again to turn off all the tubes.
F8.3	Serial port testing	
F8.3.1	Serial port send test	Serial Test function, detect serial port connection status, see 6.8.2 Serial Test for specific operations.
F8.3.2	Serial port receive test	

6.8.1 IO Test

The **IO test** function is used to test whether the connection status of the input and output ports is normal. In the weighing mode, press the key  to enter the menu, press  to enter the F8 IO test interface, and press  Confirm to enter the IO test interface. The main display is the output interface display, and the auxiliary display is the input interface display. Operate as follows:

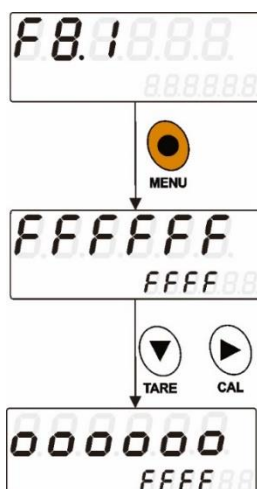
Output test:



The status of output port 1 is F. Press  or  switch to 0, the corresponding external output port 1 is valid. Press  to switch to other output ports for testing.

Input test:

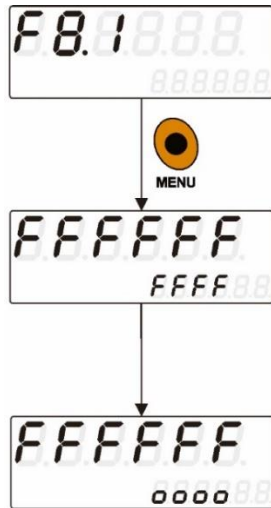



When external input 1 is valid, the corresponding input port 1, the auxiliary display bar switches from state **F** to state **O**, indicating that the connection of input port 1 is normal. Test the other input ports in the same way.

6.8.2 Serial port test

The serial port test function sends and receives data at a fixed baud rate (**38400**) and data format (**8-N-1**) to detect the status of the serial port connection. The [serial port](#) test can be conducted after the instrument is [connected](#) to the host computer in [Section 3.5](#). The steps are as follows:

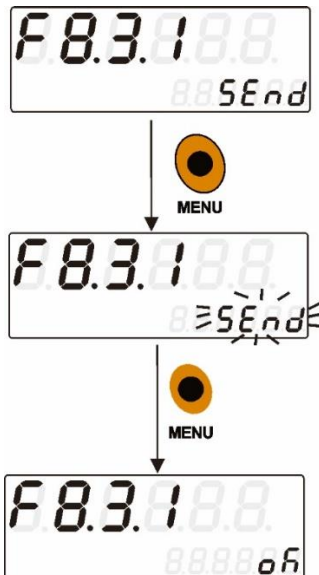
Send test:



In the "SEND" state, press the key  and "SEND" flashes. Press the key  again and "OK" is displayed for 2 seconds. Then "SEND" is displayed and data is sent. The host machine will receive the following display, serial port sending is normal.

```
@COM Test0001
@COM Test0002
@COM Test0003
@COM Test0004
```

Receiving test: Send test data (only **ASCII** code) externally to the instrument and display the data on the instrument's auxiliary display bar. The length of each frame of data cannot exceed 10 bytes.

Operation: In the "Recive" state, press the key , "Recive" flashes, press the key



again, it shows "OK" 2 seconds, then shows "-----", then the external sends HEX "40 30 31 32 33 34 35 0D 0A" to the instrument, and the instrument displays as shown in the following figure, it indicates that the serial connection is normal.





6.9 F9 USB flash drive and register parameter list

Number	Parameter Name	Initial value	Note
F9.1	Parameter export	Parm	Optional export parameters: Parm (F1-F7 parameters and F9.4 multifunction register parameters), ALL (F1-F9 and C1-C2 calibration parameters), Log (operation log). See Section 6.9.1 for details of the operations.
F9.2	Parameter import	Parm	Optional import parameters: Parm (F1-F7 parameters and F9.4 multifunction register parameters), ALL (F1-F9 and C1-C2 calibration parameters). See Section 6.9.1 for specific operations.
F9.3	Usb drive upgrade	//	Software version upgrade, see Section 6.9.2 for details.
F9.4	Multifunction register		
F9.4.1 ~ F9.4.10	Multifunction registers 1 to 10	0	Range: -99999 to 999999.
F9.5	Reset all parameters	//	Reset all parameter Settings and calibrations. Operation: Display "SYSTEM", press the MENU key SYSTEM to flash, then press the MENU key again to perform the reset
F9.6	Startup LOGO	//	Modify the startup Logo to support 8 characters only, including numbers, English letter, Space, and "-" characters.
F9.7	MAC address	Bc. 66.41. 90.00.00	Check the MAC address of the instrument.
F9.8	PN code	//	View the PN code.
F9.9	Password Management		
F9.9.1	Password-protected switch	OFF	ON and OFF are optional. When set to ON, a password is required to modify the parameters.
F9.9.2	Change password	000000	Display " Newpass -----", enter the new password for the first time, display " Newpass =====", enter the new



			password for the second time, and display PassOk , indicating that the modification was successful.
F9.10	Indicator light	USART	Optional: USRART (serial communication), Net (net weight indicator).

6.9.1 U Disk import and export

U-Disk export operation:







- 1) Insert the USB drive when the indicator ● on the main interface is on, indicating that the USB drive has been inserted. Press the key  to enter the menu to **F9.1**, and the auxiliary display selects the parameters to be exported: **Parm**(F1-F7 parameters and F9.4 multifunction register parameters), **ALL**(F1-F9 and C1-C2 calibration parameters), **Log**(operation record) are three options.
- 2) After pressing the key  to enter the password, the serial number prompt "U" indicates that the USB drive is inserted. If the USB drive is not inserted, an "Err60 (USB drive not connected)" alarm prompt will be issued. Continue pressing the key . After the auxiliary display "OK" for 2 seconds, the corresponding parameter is successfully exported to the U Disk. A sheet file named "G-2301P Data Parameter" appears in the root directory of the U Disk, recording the corresponding parameter code and parameter value.

U Disk import operation:

- 1) Place a file named "G-2301P Data Parameters" in the root directory of the USB drive and insert the USB drive. Then the indicator light ● on the main interface is on, indicating that the U Disk has been inserted. Press the key  to enter the menu to **F9.2**, and the **auxiliary** display selects the parameters to be entered: **Parm**(F1-F7 parameters and F9.4 multifunction register parameters) and **ALL**(F1-F9 and C1-C2 calibration parameters) are two options.
- 2) After pressing the key  to enter the password, the serial number prompt "U" indicates that a USB flash drive is inserted. If the USB flash drive is not inserted, an "Err60 (USB flash drive not connected)" alarm will be triggered. The auxiliary display flashes, press key  show "- - - - -", and the instrument restarts after a successful import, allowing you to check if the imported parameter values are consistent with the file.

6.9.2 U disk upgrade

1.	Place the upgrade file named G-2301PUupgrade.gm in the root directory of the USB drive;
----	---

2.	<p>The U disk can be upgraded through the main interface or in the F9.3 parameter. The method is as follows:</p> <p>1) Through the main interface: Insert the U disk into the instrument, and the main display on the main interface prompts "UPG", indicating whether an upgrade is needed. If no upgrade is needed, press  return weight display interface. If you need to upgrade, after pressing the key  and entering the password, "UPG" continues to flash and press the key  shows "Load..." It indicates that the instrument is being upgraded.</p> <p>2) Through F9.3 parameter: Press the key  to enter the menu to F9.3 interface, insert the USB drive into the instrument, press the key  to enter the password, the auxiliary display "UPG" flashes, and press the key  shows "Load..." It indicates that the instrument is being upgraded;</p>
3.	<p>About 10 seconds after the upgrade is completed, it will automatically restart and enter the main interface.</p>

6.10 F10 Maintain the list of function parameters

When the parameter working mode is set to "Force" Mode, the parameters will be visible.

Number	Initial Value	Explanation
F10	None	
F10.1	None	<p>Hold Mode.</p> <p>0- None: No hold function.</p> <p>1- PK: Peak hold; (After the corresponding trigger condition is met, the maximum weight is retained.)</p> <p>2- VL: Valley hold; (After the corresponding trigger condition is met, the minimum weight is retained.) .</p> <p>3- PK-VL: Peak-valley hold; (Retains the difference between the maximum and minimum weights.)</p> <p>4- S: Sample value hold; (Retains the real-time weight value upon triggering.)</p> <p>5- STAB: Stable hold; (Not affected by the "F10.2 Hold Trigger Condition". When the weight exceeds the zero zone value and stabilizes, the main display remains unchanged, the sub-display shows "-----", and the hold is canceled immediately upon returning to the zero zone (hold value resets to 0).)</p> <p>6- PKVL: Peak-valley hold; (When the current weight is greater than zero and the corresponding trigger condition is met, peak trigger display is activated; when the current weight is less than zero and the corresponding trigger condition is met, valley trigger display is activated.)</p> <p>Note When F10.1 is set to "None", F10.2 and F10.3 will be hidden.</p>

F10.2	Ext	Trigger Condition Options Ext: External Trigger (Triggered by keys, digital input, or commands); Zero: Zero Zone Trigger (Only valid for peak hold, valley hold, and peak-valley hold).
F10.3	100	Zero Zone Trigger Value (Effective when triggered in the zero zone); For peak hold: Activated when the display value exceeds the zero zone; For valley hold: Activated when the display value is below the negative zero zone value; When the display value returns to the zero zone, the hold ends, and the meter retains the value until the next hold is activated). Range: 0~999999

Function Description:

(1) When the trigger condition of F10.2 is set to "Ext" (external trigger), F10.1 functions 1-4 and 6 will take effect.

If F10.1 is set to "1" for peak retention, when the button, switch quantity Tirg_H (trigger retention), or switch quantity Lv_H (level retention) is valid or communication is enabled, the instrument will start the retention function, retaining the maximum weight value displayed by the instrument until the button or switch quantity input becomes invalid or communication is turned off. The retention function will be cancelled, but the "retention value" will be saved for the next start of the retention function.

(2) When F10.2 selects the trigger condition as "1" for zero zone trigger, F10.3 "zero zone value" is valid, and F10.1 functions 1-2 and 6 will take effect.

If F10.1 is set to "1" for peak retention, as long as the real-time weight value exceeds the zero zone value (100), continuous retention will be initiated, retaining the maximum weight value displayed by the instrument. When the real-time weight value returns to the zero zone value (≤ 100), the retention ends, and the instrument saves the "retention value" for the next start of the retention function.

If F10.1 is set to "2" for valley value retention, as long as the real-time weight value is lower than the negative zero zone value (-100), continuous retention will be initiated, retaining the minimum weight value displayed by the instrument. When the real-time weight value is greater than the zero zone value (≥ -100), the retention ends, and the instrument saves the "retention value" for the next start of the retention function.

(3) During the retention process, an auxiliary display can be set as "Hold" to show the retention result. The "HOLD" status indicator light on the front panel will be on to indicate that the retention function is enabled.

Chapter 7 Communication Protocol and Addresses

7.1 Modbus Protocol

7.1.1 Description of function codes and exception codes

Function codes supported by the instrument

Function codes	Name	Note
03	Read registers	Read up to 125 registers at a time
06	Write to a single register	Use this function code to write a single register
16	Write multiple registers	This instrument command only supports writing to dual registers. When writing, the address must be aligned. It is not allowed to write to only a part of the dual registers. When reading, only a part is allowed to be read.
01	Read coil	Note that this length is in bits.
05	Write coil	

Note: This instrument only supports the above **MODBUS** function code. The instrument will not respond when other function code are sent to it.

Abnormal code response

Code	Name	Meaning
02	Illegal data address	For this instrument, the error code represents that the data address received is not allowed.
03	Illegal data value	The data written does not fall within the permitted range.
04	Slave failure	An irrecoverable error occurs when the instrument is attempting to perform the requested operation.
07	Unsuccessful programming request	For the instrument, the command received cannot be executed under the current conditions.

7.1.2 Transmission Mode

RTU mode

(1) When RTU mode is selected for communication, every 8 bits (1 byte) in the message are transmitted as 2 4-bit hexadecimal characters.

(2) Marking the end of a frame requires an interval of more than 3.5 characters. For a more reliable end, it is recommended to use an interval of more than 4.0 characters.

The specific protocol for this approach is as follows:

Supported data formats: **8** data bits, **1** stop bit, even parity (**8-E-1**)

8 data bits, **1** stop bit, odd parity (**8-O-1**)

8 data bits, **1** stop bit, no parity (**8-n-1**)

Code: Binary

ASCII mode

When **ASCII** mode is selected for communication, every **8** bits (**1** byte) in a message are transmitted as **2 ASCII** characters.

The specific protocol for this mode is as follows:

Supported data formats: **8** data bits, **1** stop bit, even parity (**8-E-1**)

8 data bits, **1** stop bit, odd parity (**8-O-1**)

8 data bits, **1** stop bit, no parity (**8-n -1**)

Code: **ASCII** code

7.1.3 Modbus communication Address table

PLC address	Data Type	R/W	Meaning	instruction	
40001-40002	Int32	R	Displayed weight	Signed, integer	
40003	Uint 16	R	Weight status flag bit	Position	Explanation
				D15	Network communication Heartbeat
				D12~D14	Reserve
				D11	The current weight is the theoretical value
				D10	ADC failure
				D9	The current is net weight
				D8	loadcell negative overflow
				D7	loadcell positive overflow
				D6	Weight negative overflow
				D5	Weight positive overflow
				D4	Overflow status
				D3	Weight is negative
				D2	Zero
				D1	The millivolt is unstable
D0	Weight unstable				
40004	Reserve				
40005-40006	int32	R	Gross weight	Signed, integer	
40007-40008	int32	R	Net weight	Signed, integer	
40009-40010	int32	R	Tare weight	Signed, integer	
40011-40012	float	R	Floating-point numbers displayed weight	Display weight, with signed and floating-point types	
40013-40014	float	R	Floating-point gross weight	Signed, floating-point type	
40015-40016	float	R	Floating-point net weight	Signed, floating-point type	
40017-40018	float	R	Floating-point tare weight	Signed, floating-point type	
40019-40020	float	R	Loadcell voltage	Signed, floating-point type	
40021-40022	float	R	Relative zero voltage	Signed, floating-point type	
40023-40024	int32	R	Analog	Signed, integer	
40025	Uint 16	R	IO status	D14~	Reserve

				D15	
				D13	Output 7 status - Optional
				D12	Output 6 status - Optional
				D11	Output 5 status - Optional
				D10	Output 4 status - Optional
				D9	Output 3 status
				D8	Output 2 status
				D7	Output 1 status
				D6	PWM output 3 status
				D5	PWM output 2 status
				D4	PWM output 1 status
				D3	Input 4 status
				D2	Input 3 status
				D1	Input 2 status
				D0	Input 1 status
40026	Reserve				
40027	Uint 16	R	Process status bits	D15	IO test status
				D6 ~D14	Reserve
				D5	Comparator 6 achieves status
				D4	Comparator 5 achieves status
				D3	Comparator 4 achieves status
				D2	Comparator 3 achieves status
				D1	Comparator 2 achieves status
				D0	Comparator 1 achieves status
40028	Reserve				
40029	Uint 16	R	Error Code 1	D15	Print is prohibited if no print protocol is selected
				D14	Division overprecision
				D13	Calibration lock
				D12	Unstable during calibration, waiting to stabilize
				D11	Perform remote calibration when it is disabled
				D10	The previous weight point is not calibrated
				D09	Beyond the minimum resolution (less than 0.1uV per division)
				D08	Weight input exceeds the maximum range
				D07	The weight input cannot be zero
				D06	Weight calibration is less than zero or the previous calibration point
				D05	The loadcell is overflowing during weight calibration

				D04	Loadcell Negative overflow during weight calibration
				D03	Weight calibration is unstable
				D02	Loadcell positive overflow during zero calibration
				D01	Loadcell negative overflow during zero calibration
				D00	Zero calibration is unstable
40030	Uint 16	R	Error Code 2	D06~D15	Reserve
				D05	Automatic weight correction factor out of range
				D04	The switch is not on when automatically correcting the weight factor
				D03	The result is less than or equal to 0 when the weight factor is automatically corrected
				D02	There is overflow when automatically correcting the weight factor
				D01	Does not allow automatic weight correction in net status
				D00	The weight is unstable when the weight factor is automatically corrected
40031	Uint 16	R	Error Code 3	D15	Calibration error
				D14	Unstable operation, waiting to stabilize
				D13	The remote tare operation allow switch was not turned on when tare remotely
				D12	Do not perform continuous tare
				D11	The weight is negative when taring
				D10	The loadcell is overflowing when taring
				D09	Negative overflow of the loadcell when taring
				D08	Unstable during taring
				D07	Net weight status is not allowed to be reset to zero
				D06	Reserve
				D05	Loadcell positive overflow when zeroing
				D04	Loadcell negative overflow when zeroing
				D03	Unstable at zeroing
				D02	Zero out of range
				D01	Unstable when Power-on zero
D00	Power-on zero out of range				
40032 ~ 40100	Reserve				
Basic Parameters					
40101-40102	Uint 32	R/W	Power-on zero	Initial value: 0 (disable power-on zero function); Range: 0 to 99% (full scale percentage)	

			range	
40103-40104	Uint 32	R/W	Power-off save Zero	Initial value: 0:OFF ; Optional 0:OFF 1:ON
40105-40106	Uint 32	R/W	Zero range	Initial value: 20 ; Range: 0 to 99% (full scale percentage)
40107-40108	Uint 32	R/W	Zero tracking range	Initial value: 1 ; Range: 0 to 99d
40109-40110	Uint 32	R/W	Zero tracking time	Initial value: 1000mss ; Range: 1000 to 60,000 ms
40111-40112	Uint 32	R/W	Stable range	Initial value: 1d ; Range: 0 to 99d
40113-40114	Uint 32	R/W	Judging stable time	Initial value: 1000ms ; Range: 100 to 5000ms
40115-40116	Uint 32	R/W	Digital filter levels	Initial value: 5 ; Range: 0 to 9
40117-40118	Uint 32	R/W	Remove Vibration filter	Initial value: 0 ; Range: 0 to 99d
40119-40120	Uint 32	R/W	AD sampling speed	Initial value: 0 ; Range: 0 to 10
40121-40122	Uint 32	R/W	Loadcell signal range	0:0-5 mV; 1:0-10mV; 2:0-15mV, 3: -5-5mV, 4: -10-10mV, 5:-15-15mV, default 5:-15-15mV
40123-40200	Reserved			
Tare weight parameter				
40201-40202	Uint 32	R/W	Tare weight operation switch	Initial value: 0:OFF ; Optional 0:OFF 1:ON
40203-40204	Uint 32	R/W	Tare weight memory function	Initial value: 0:OFF ; Optional 0:OFF 1:ON
40205-40206	Uint 32	R/W	Negative net return to zero function	Initial value: 0:OFF ; Optional 0:OFF 1:ON
40207-40208	Float	R/W	Preset tare weight	Initial value: 0 ; Range: 0 to 999999
40209-40210	Uint 32	R/W	Automatic tare switch	Initial value: 0:OFF ; Optional 0:OFF 1:ON
40211-40212	Float	R/W	Automatic tare threshold	Initial value: 0 ; Range: 0 to 999999
40213-40214	Uint 32	R/W	Automatic clear tare switch	Initial value: 0:OFF ; Optional 0:OFF 1:ON
40215-40216	Float	R/W	Automatic remove tare threshold	Initial value: 0 ; Range: 0 to 999999
40217-40300	Reserved			

Calibration Parameters				
40301-40302	Uint 32	R/W	Unit	Initial value: 1 ; Range: 0:g; 1:kg; 2:t
40303-40304	Uint 32	R/W	Division	Initial value: 5:1 ; Range: 0 to 23 ; Corresponding as follows: 0:50 1:20; 2:10; 3:5; 4:4; 5:1; 6:0.1; 7:0.2; 8:0.5; 9:0.01; 10:0.02; 11:0.05; 12:001; 13:0.002; 14:005; 15:0.010 16:0.020; 17:0.050; 18:0.0001; 19:0002; 20:0005; 21:00001; 22:00002; 23:00005.
40305-40306	Float	R/W	Maximum Capacity	Initial value: 10 ; Range: 1~(100000 * division)
40307-40308	Float	R/W	Auto zero calibration	When writing 1, the system automatically acquires the loadcell zero point calibration voltage; Read: Get the current loadcell voltage
40309-40310	Float	R/W	Manual zero calibration	Write: Numerically calibrated zero point (fixed:4 decimal points); Range: -15mv-15mv
40311-40312	Float	R/W	Gain calibration point -1	Write: The weight value of the weights is calibrated against the calibration weight point 1 Read: Get the relative voltage value 1
40313-40314	Float	R/W	Gain Calibration point -2	Write: The weight value of the weights is calibrated against the calibration weight point 2 Read: Get the relative voltage value 2
40315-40316	Float	R/W	Gain calibration point -3	Write: The weight value of the weights is calibrated against the calibration weight point 3 Read: Get the relative voltage value 3
40317-40318	Float	R/W	Gain calibration point 4	Write: The weight value of the weights is calibrated against the calibration weight point 4 Read: Get the relative voltage value 4
40319-40320	Float	R/W	Gain calibration point 5	Write: The weight value of the weights is calibrated against point 5 of the calibration weight Read: Get the relative voltage value 5
40321-40322	Uint 32	R/W	Loadcell sensitivity	Range: 0.0001-3.9999 , default: 2.0000
40323-40324	Float	R/W	Total loadcell range	Range: 1-999999 , default: 10000
40325-40326	Uint 32	R/W	Theoretical value switch	Initial value: 0:OFF ; Optional 0:OFF 1:ON
40327-40328	Float	R/W	Weight correction coefficient	Range 1-999999, default: 100000
40329-40330	Uint 32	R/W	Auto-	Initial value: 0:OFF ; Optional 0:OFF 1:ON

			correct weight factor switch	
40331-40332	Float	R/W	Auto correct changing weight	Less than the maximum pressure value
40333-40400	Reserved			
Communication parameters				
40401-40402	Uint 32	R/W	Slave ID	Initial value: 1 , parameter range: 1 to 99
40403-40404	Uint 32	R/W	Baud rate	Initial 5:38400; 0:1200/1:2400/2:4800/3:9600/4:19200/5:38400/6:57600/7:115200
40405-40406	Uint 32	R/W	Communication Protocol	Initial value: 0:Modbus RTU ; Optional: 0: MD._RTU ; 1:MD._ASC ; 2:CS._RDP ; 3:CS._tt ; 4:CS._RE ; 5:CS._SP1 ; 6:CS.EASY ; 7:PRINT . The PRINT protocol is only supported on RS232 printer
40407-40408	Uint 32	R/W	Data format	Initial value: 1:8-E-1 . Range: 0:8-N-1 ; 1:8-E-1 ; 2:8-O-1 ; 3:7-E-1 ; 4:7-O-1 (meaning: data bit - parity - stop bit)
40409-40410	Uint 32	R/W	Two-word format	Initial value: 0 ; 0:H-L ; 1:L-H
40411-40412	Uint 32	R/W	Continuous sending interval	Range: 10-6000ms, default: 20ms
40413-40414	Uint 32	R/W	TT protocol checksum switch	0: Do not send the check; 1: Send verification. Default: 0
40415-40450	Reserved			
40501-40508	Uint 32	R/W	Instrument IP segment 1 to IP segment 4	IP address. Initial value: 192.168.0.1 Range: 0.0.0.0 to 255.255.255.255
40509-40516	Uint 32	R/W	Subnet mask 1-4	Initial value: 255.255.255.0 Range: 0.0.0.0 to 255.255.255.255
40517-40524	Uint 32	R/W	Gateway 1 to 4	Initial value: 192.168.0.1 Range: 0.0.0.0 to 255.255.255.255
40525-40526	Uint 32	R/W	Connect 1 port	Initial value: 502 , range: 1-65535, network communication port number setting, 0 indicates closing the connection.
40527-40528	Uint 32	R/W	Connect 1 Communication Protocol	It can be set for standard network ports, including: Protocols: 0- Modbus/TCP , 1-GM-Cont/TCP , default 0-Modbus/TCP .

40529-40530	Uint 32	R/W	Connect 1 double word mode	It can be set with the standard network port in high and low byte mode for Modbus/RTU use. 0-AB-CD, 1-CD-AB , default: 0-AB-CD
40531-40532	Uint 32	R/W	Connect 1 send interval	When the communication protocol is 1-GM-Cont , this parameter is used to set the interval time for continuous sending. Range : 0-5000ms , default : 20ms
40533-40540	Uint 32	R/W	Connect 2 communication parameters	Except for the initial value of port number being 0 , the rest refer to connection port 1 , register address 40525-40532 parameter description
40541-40548	Uint 32	R/W	Connect 3 Communication parameters	
40549-40556	Uint 32	R/W	Connect 4 communication parameters	
40557-40558	Uint 32	R/W	Port TT protocol checksum switch	Initial value: 0-off ; Range: 0- off, 1-on .
40559-40560	Reserve			
40562-40561	Uint 32	R/W	Bus data type	0: int, 1: float , initial value: 0
Analog parameters				
40601-40602	Uint 32	R/W	Analog output mode	0:4-20mA; 1:0-10v; 2: -10-10V; 3: User-i; 4: User-u; Default: 0:4-20mA
40603-40604	Uint 32	R/W	Analog associated weight Settings	0: Associated display, 1: gross weight, 2: net weight, default 0
40605-40606	Uint 32	R/W	Customize minimum output - current	Current: 0-24mA, default: 0mA
40607-40608	Uint 32	R/W	Custom zero-point output - current	Current: 0-24mA, default: 4mA
40609-40610	Uint 32	R/W	Customize maximum range output - current	Current: 0-24mA, default: 20mA
40611-40612	Uint 32	R/W	Customize maximum output - current	Current: 0-24mA, default: 24mA
40613-40614	Uint 32	R/W	Customize minimum output-voltage	Voltage: -10V-10V, default: 0V
40615-40616	Uint 32	R/W	Custom zero-point output - voltage	Voltage: -10V-10V, default: 0V
40617-40618	Uint 32	R/W	Customize maximum range output - voltage	Voltage: -10V-10V, default: 10V
40619-40620	Uint 32	R/W	Customize maximum output-voltage	Voltage: -10V-10V, default: 0V
40621-40630	Retain			
40631-40632	Uint 32	R/W	Analog calibration switch	Range:0-1, default :0, write 1 to enable analog calibration

40633-40634	Uint 32	R/W	Analog calibration point 1 switch	Range:0-1, default :0, write 1 to enable calibration point 1
40635-40636	Uint 32	R/W	Analog calibration point 1 current/voltage	Write the current or voltage corresponding to the output of the current DA code, calibrate the reference point, high and low words need to be written simultaneously. Current: 0-24000, default 1000; Voltage: 0-10000, default: 1000
40637-40638	Uint 32	R/W	Analog calibration point 2 switch	Range:0-1, default :0, write 1 to enable calibration point 1
40639-40640	Uint 32	R/W	Analog calibration point 2 current/voltage	Write the current or voltage corresponding to the output of the current DA code, calibrate the reference point, high and low words need to be written simultaneously. Current: 0-24000, default 4000; Voltage: 0-10000, default: 3000
40641-40642	Uint 32	R/W	Analog calibration point 3 switch	Range :0-1, default :0, write 1 to enable calibration point 1
40643-40644	Uint 32	R/W	Analog calibration point 3 current/voltage	Write the current or voltage corresponding to the output of the current DA code, calibrate the reference point, high and low words need to be written simultaneously. Current: 0-24000, default 12000; Voltage: 0-10000, default: 5000
40645-40646	Uint 32	R/W	Analog calibration point 4 switch	Range :0-1, default :0, write 1 to enable calibration point 1
40647-40648	Uint 32	R/W	Analog calibration point 4 current/voltage	Write the current or voltage corresponding to the output of the current DA code, calibrate the reference point, high and low words need to be written simultaneously. Current: 0-24000, default 20000; Voltage: 0-10000, default: 7000
40649-40650	Uint 32	R/W	Analog calibration point 5 switch	Range :0-1, default :0, write 1 to enable calibration point 1
40651-40652	Uint 32	R/W	Analog calibration point 5 current/voltage	Write the current or voltage corresponding to the output of the current DA code, calibrate the reference point, high and low words need to be written simultaneously. Current: 0-24000, default 22000; Voltage: 0-10000, default: 9000

40653 ~ 40700	Reserved		
IO Function parameters			
40701-40702	Uint 32	R/W	Input port Function definition 1
40703-40704	Uint 32	R/W	Input debouncing time 1
40705-40706	Uint 32	R/W	Input port function definition 2
40707-40708	Uint 32	R/W	Input debouncing time 2
40709-40710	Uint 32	R/W	Input Port Function Definition 3
40711-40712	Uint 32	R/W	Input debouncing time 3
40713-40714	Uint 32	R/W	Input Port Function Definition 4 (including PWM)
40715-40716	Uint 32	R/W	Input debouncing time 4 (with PWM)
40717-40750	Reserved		
40751-40752	Uint 32	R/W	Output port Function Definition 1 (including PWM)
40753-40754	Uint 32	R/W	Output Port Function Definition 2 (including PWM)
40755-40756	Uint 32	R/W	Output Port Function Definition 3 (including PWM)
40757-40758	Uint 32	R/W	Output port function definition 4
40759-40760	Uint 32	R/W	Output port function definition 5
40761-40762	Uint 32	R/W	Output port function definition 6
40763-40764	Uint 32	R/W	Output port function definition 7
40765-40766	Uint 32	R/W	Output port function definition 8
40767-40768	Uint 32	R/W	Output port Function definition 9
40769-40770	Uint 32	R/W	Output port function
<p>Initial value: 0 - None; Input port function definition range: 0 - None (no definition); 1 - Zero (clear zero); 2 - CAL-Zr (calibrate zero point); 3 - Tare (remove weight); 4 - C-Tare (clear weight); 5 - Net (switch between gross and net weight); 6 - COMP.Go (enable comparison point); 7 - Print (print); 8 - P.EptIn (print paper movement); 9 - Key-L (keyboard lock); 10 - CAL-L (calibration lock); 11 - Lv_H (level hold); 12 - Tirg_H (trigger hold) Among 11 and 12, the force measurement mode can be selected. Shake-off time range: 0 - 1000ms, initial value: 5ms</p> <p>Initial value: 0 - None; Output port function definition range: 0 - None (undefined); 1 - Stab (stable); 2 - Zero (zero point); 3 - OFL (overflow); 4 - Net (net weight); 5 - Print (printing in progress); 6 - SIGN (negative weight); 7 - Hbeat (communication heartbeat); 8 - COMP1 (Comparator 1); 9 - COMP2 (Comparator 2); 10 - COMP3 (Comparator 3); 11 - COMP4 (Comparator 4); 12 - COMP5 (Comparator 5); 13 - COMP6 (Comparator 6).</p>			

			definition 10	
40725-40800	Reserved			
Comparator parameters				
40801-40802	Uint 32	R/W	Comparator Comparison mode 1-	Initial value: 1 - Weight is less than or equal to; During comparison mode: Parameter range: 0 - 6, 0 - OFF; 1 - $\leq CV1$ (less than or equal to); 2 - $\geq CV1$ (greater than or equal to); 3 - C1 - C2 (between); 4 - -C1.C2 - (not between).
40803-40804	Float	R/W	Comparator Compare value 1 1-	Initial value: 0; Comparison value 1, signed number, range -999999-999999.
40805-40806	Float	R/W	Comparator Compare values 2 1-	Initial value: 0; Comparison value 2, signed number, range:-999999-999999, used when comparing two values, greater than comparison value 1.
40807-40808	Float	R/W	Comparator 1- Achieve mode	Initial value: 0- Delayed mode; Range: 0-1, corresponding to: 0- delayed mode, 1- delayed output after weight stabilization
40809-40810	Uint 32	R/W	Comparator 1- Achieve output delay	Minimum achieve judge time, initial value: 0ms, range: 0-10000ms;
40811-40812	Uint 32	R/W	Comparator 1- Failure mode	Initial value: 0- Delay mode; Range: 0-1, corresponding to: 0- delay mode, 1- delay invalid after weight stabilization
40813-40814	Uint 32	R/W	Comparator 1- Turn off output delay	Minimum decision time for failure, initial value: 0ms, range 0-10000ms;
40815-40828	Uint 32	R/W	Comparator 2 parameters	Refer to the comparator 1 parameter description and the corresponding data type
40829-40842	Uint 32	R/W	Comparator 3 parameters	
40843-40856	Uint 32	R/W	Comparator 4 parameters	
40857-40870	Uint 32	R/W	Comparator 5 parameters	
40871-40884	Uint 32	R/W	Comparator 6 parameters	
40885-41000	Reserve			
I/O test parameters				
41011	Uint 16	R/W	IO test switch	Write 1 to start the test and write 0 to turn it off
41012	Uint 16	R	Input I1 test	

41013	Uint 16	R	Input I2 test	1 input is valid, 0 input is invalid
41014	Uint 16	R	Input I3 test	
41015	Uint 16	R	Input PWM-I4 test	
41016	Uint 16	R/W	IO output PWM-O1 test	Write 1 output valid, write 0 output invalid
41017	Uint 16	R/W	IO output PWM-O2 test	
41018	Uint 16	R/W	IO output PWM-O3 test	
41019	Uint 16	R/W	I/O output O4 test	
41020	Uint 16	R/W	I/O output O5 test	
41021	Uint 16	R/W	I/O output O6 test	
41022	Uint 16	R/W	IO output O7 test	
41023	Uint 16	R/W	IO output O8 test	
41024	Uint 16	R/W	I/O output O9 test	
41025	Uint 16	R/W	IO output O10 test	
41026-41040	Reserve			
Multifunction register parameter address				
41041-41042	Uint 32	R/W	Multifunction Register 1	Range: -99999-999999, default: 0
41043-41044	Uint 32	R/W	Multifunction Register 2	
41045-41046	Uint 32	R/W	Multifunction Register 3	
41047-41048	Uint 32	R/W	Multifunction Register 4	
41049-41050	Uint 32	R/W	Multifunction Register 5	
41051-41052	Uint 32	R/W	Multifunction Register 6	
41053-41054	Uint 32	R/W	Multifunction Register 7	
41055-41056	Uint 32	R/W	Multifunction Register 8	
41057-41058	Uint 32	R/W	Multifunction Register 9	
41059-41060	Uint 32	R/W	Multifunction Register 10	
41061-41062	Uint 32	R/W	Communication indicator	0: USART (Serial port indicator); 1: NET(network port indicator), default: 0 When TIA Portal assigns device names and the device LED light flashes after selecting device, only the communication indicator light selects "Net", will flash at a frequency of 500Hz
41063-41100				
41101-41102	R	float	Maintain the result	Note: When peak hold is active, read the held peak value; when valley hold is active, read the held valley value. Others are analogous.

41103-41104	R/W	uint32_t	Maintain the mode	Default value: 0; Range:0~6, 0- None: No hold function; 1- PK: Peak hold; 2- VL: Valley hold;; 3- PK-VL: Peak-valley hold;; 4- S: Sample value hold; 5- STAB: Stable hold; 6- PKVL: Peak&Valley value hold.
41105-41106	R/W	uint32_t	Trigger condition	Default value: 0; Range:0~1, 0- Ext: External trigger hold.; Zero: Zero-zone triggering;
41107-41108	R/W	float	Trigger zero value	0~999999, Default value 100
41109-41110	R/W	uint32_t	Trigger hold	0: Stop maintaining the state 1: Activate the holding state
41111-41200	Reserve			
Print Parameters				
41201-41202	Uint 32	R/W	Number of header information lines	Range: 0-4, default: 0
41203-41204	Uint 32	R/W	Number of tail information lines	Range: 0-4, default: 0
41205-41206	Uint 32	R/W	Auto print feed paper lines	Range: 0-8, default: 2
41207-41208	Uint 32	R/W	Print data content	Range: 0-3 default: 3 0- only gross weight 1- gross weight + net weight 2- gross weight + tare weight 3- Gross weight + net weight + tare weight
41209-41210	Uint 32	R/W	Print time format	Range: 0-3 default: 3 0- no 1- only time, 2- only date 3- Date&Time (excluding seconds)
41211-41212	Uint 32	R/W	Print format	Range: 0-1, default: 0, 0-16 character width Chinese; 0-16 character width English
41213-41214	Uint 32	R/W	Header information first line characters 1-4	Print the character content of the message (16 characters); Support all displayable Ascii codes, default: 0x2D2D (Some ASCII codes may not print and display)
41215-41216	Uint 32	R/W	Header information first line character 5-8	
41217-41218	Uint 32	R/W	Header information first line character 9-12	
41219-41220	Uint 32	R/W	Header information Line 1 character 13-16	
41221-41228	Uint 32	R/W	Header information Line 1 to 16	
41229-41236	Uint 32	R/W	Header information Line 3 characters 1-16	
41237-41244	Uint 32	R/W	Header information Line 4 characters 1-16	
41245-41246	Uint 32	R/W	Tail information first line characters 1-4	
41247-41248	Uint 32	R/W	Tail information first line character 5-8	
41249-41250	Uint 32	R/W	Tail information first line character 9-12	
41251-41252	Uint 32	R/W	Tail information first line character 13-16	
41253-41260	Uint 32	R/W	Tail information Line 2 characters 1-16	
41261-41268	Uint 32	R/W	Tail information line 3 characters 1-16	

41269-41276	Uint 32	R/W	Tail information line 4 characters 1-16	
Time setting				
41301	Uint16	R/W	Time Zone	The range is from -120 to 120, and the default time zone value is 80. A minimum interval of 5 can be set, representing Zone 12 east to Zone 12 West, with an interval of 0.5 time zones.
41302	Uint16	R/W	Date format	Range: 0-1, 0-YY.MM.DD; 1-DD.MM.YY, default: 0-YY.MM.DD
41303	Uint16	R/W	year	Range: <2099, default: 2000
41304	Uint16	R/W	month	Range: 1-12, default: 1
41305	Uint16	R/W	day	Range: 1-31, default: 1
41306	Uint16	R/W	hour	Range: 0-23, default: 0
41307	Uint16	R/W	minute	Range: 0-59, default: 0
41308	Uint16	R/W	Second	Range: 0-59, default: 0
41309	Reserve			
Reset parameter address				
48001-48002	Uint 32	W	Basic parameter reset	Write 1 to perform the corresponding reset operation Read out all zeros
48003-48004	Uint 32	W	Serial port parameter reset	
48005-48006	Uint 32	W	Network parameter reset	
48007-48008	Uint 32	W	Analog parameter reset	
48009-48010	Uint 32	W	Comparator parameter reset	
48011-48012	Uint 32	W	IO parameter reset	
48013-48014	Uint 32	W	Weight calibration parameter reset	
48015-48016	Uint 32	W	Analog calibration reset	
48017-48018	Uint 32	W	Reset all calibration parameters (including weight and analog calibration)	
48019-48020	Uint 32	W	Reset all parameters	
48021-48050	Reserve			
48051-48056	Uint16	R/W	Edit startup logo characters 1-8	(8 characters); The sequence corresponds to the first to eighth characters of the startup logo and requires writing Ascii code, range: 0-9,A-Z,a-z , space, '-'
48057 ~ 48080	Reserve			
Function Operations				
48081-48082	Uint16	W	IO Function 1: zero	Write 1 to perform the operation Read out all 0
48083-48084	Uint16	W	IO Function 3: tare	
48085-48086	Uint16	W	IO Function 4: Clear tare	
48087-48088	Uint16	W	IO Function 5: Gross/Net weight switch	
48089-48090	Uint16	W	IO Function 2: Zero calibration	
48091-48092	Uint16	W	IO Function 7: Print	
48093-48094	Uint16	W	IO Function 8: Print feed paper	
Instrument system information area				

410001-410002	Uint 32	R	Software version	If you read 10000 , it is version 01.00.00
410003-410004	Uint 32	R	Compilation date	Read-only
410005-410017	Uint16	R	Instrument serial number 13 characters	Range: 0-9, default: 0
410018-410029	Uint16	R	Instrument 138 encodes 12 characters	Read-only
410030	Uint16	R	The DAC is equipped with an optional additional board	Read-only
410031	Uint16	R	Optional add-on board for the network port	Range 0-2,0 for none, 1 for standard network port, 2 for ProfiNet
410032	Uint16	R	IO Optional add-on board	Range 0- 1,0 indicates no IO add-on board, 1 indicates IO add-on board
410032 ~ 410050	Reserve			
410051 ~ 410056	Uint16	R	Instrument Mac1 address segment 1 to 4	MAC address, default: BC: 66:41:9 0:00:00
Coil address				
00001	Bool	R/W	IO Function 1: Zero	Write 1 to perform the operation Read out all 0
00002	Bool	R/W	IO Function 3: Tare	
00003	Bool	R/W	IO Function 4: Clear tare	
00004	Bool	R/W	IO Function 5: Gross/Net weight switching	
00005	Bool	R/W	IO Function 2: Calibrating zero point	
00006	Bool	R/W	IO Function 7: Print	
00007	Bool	R/W	IO Function 8: Print feed paper	
00008 ~ 00100	Reserved			
Reset parameter area				
00101	Bool	W	Basic parameter reset	Write 1 to perform the corresponding reset operation, and read out all 0
00102	Bool	W	Serial port parameter reset	
00103	Bool	W	Network parameter reset	
00104	Bool	W	Analog parameter reset	
00105	Bool	W	Comparator parameter reset	
00106	Bool	W	IO parameter reset	
00107	Bool	W	Weight calibration parameter reset	
00108	Bool	W	Analog calibration reset	
00109	Bool	W	Reset all calibration parameters (including weight and analog calibration)	
00110	Bool	W	Reset all parameters	
00111 ~ 00200	Reserved			
00201	Bool	R	Input the I1 status	Read-only, readout returns the status bits of each input port. 0 : Invalid; 1 Valid
00202	Bool	R	Input the I2 status	
00203	Bool	R	Input the I3 status	
00204	Bool	R	Input the PWM-I1 status	

00205 ~ 00250	Reserved		
00251	Bool	R	Output PWM-O1 status
00252	Bool	R	Output PWM-O2 status
00253	Bool	R	Output PWM-O3 status
00254	Bool	R	Output O1 status
00255	Bool	R	Output O2 status
00256	Bool	R	Output O3 status
00257	Bool	R	Output O4 status
00258	Bool	R	Output O5 status
00259	Bool	R	Output O6 status
00260	Bool	R	Output O7 status
00261 ~ 00300	Reserved		

Switch status bit, read-write, write **1** to set the output port status to valid.
0: Invalid; **1** Valid

7.2 RDP Protocol

In this mode, no commands need to be sent to the weighing indicator, and the indicator automatically sends the collected data to the host computer.

Return data frame format description:

STX	Gross/net weight status	Status position	Displayed weight	ETX
02H	31H/30H	2 positions	6	03H

Among them:

STX - **1** bit, fixed to **02H**;

Gross/net weight status - **1** bit, gross weight: **31H**; Net weight: **30H**;

Displayed weight - 6 bit, including a negative sign or space; The weight data is "-----" when the weight overflows or is incorrect.

ETX -- 1 bit, fixed to **03H**

Status bits are described as follows:

Status 1

D7	D6	D5	D4	D3	D2	D1	D0
				Overflow		Stable	Zero
Fixed 0	Fixed 0	Fixed 1	Fixed 1	1 - Overflow/error 0 - Normal	Fixed 0	0 - unstable 1 - Stable	0 - non-zero 1 -zero

Status 2

D0	0	0	1	1
D1	0	1	0	1
Decimal point	x	.x	.xx	.xxx
D2 D6 D7 is 0(unchanged) D3 D4 D5 is 1(unchanged)				

7.3 tt Toledo Protocol

Working Parameter **F2.3** Select the "tt" protocol, and the instrument will send data in a continuous method using the Toledo protocol.

The format of the Toledo continuous transmission is as follows:

STX	A	B	C	Displayed weight	reserve	CR	Check code
------------	----------	----------	----------	-------------------------	----------------	-----------	-------------------

Among them:

STX starter -- 02H

The status word **A** is defined as follows:

D0	0	1	0	1	0	1
D1	1	1	0	0	1	1
D2	0	0	1	1	1	1
Decimal point	x	.x	.xx	.xxx	.xxxx	.xxxxx
D3 D4 D6 0(unchanged) D5 1(unchanged)						

The state word **B** is defined as follows:

D6	D6	D5	D4	D3	D2	D1	D0
	Instrument status		Unit	Stable	Overflow	Symbol	Gross weight
Fixed 0	Fixed: 0	Fixed: 1	1-lb 0-kg (This bit is invalid in other unit)	1 - Unstable 0 - stable	1 - Overflow 0 - Normal	1 - negative 0 - positive	0- gross weight; 1- Net weight;

Status word **C** is defined as follows:

D0	0	1	0	1	0	1	0	1
D1	0	0	1	1	0	0	1	1
D2	0	0	0	0	1	1	1	1
Instructions	lb or kg, determined by D4 of the status word B	Gram (g)	Metric tons (t)	Ounce (oz)	Troy ounce (ozt)	Bennewitt (dwt)	ton	Custom Unit

The remaining bits D3 to D7 are fixed to 0

Displayed weight - **6** bytes, no sign or decimal point. Replace the leading 0 with Space;

Reserve - **6** bytes, all for **30H**;

CR - **1** byte, **0DH**;

Checksum - used to check for errors in the transmitted data. See the CRC calculation instructions for specific calculations.

7.4 Easy-Cont Protocol

In this mode, no commands need to be sent to the weighing display, and the display automatically sends the collected data to the upper computer.

Return data frame format description:

STX	Status bit	BCD1	BCD2	BCD3
1 bit	1 bit	Weight data 1, 2 bits	Weight data 3, 4 bits	Weight data 5, 6 bits

Among them:

STX -- **1** byte, fixed to 0xFF;

The status bit is described as follows:

D0 to D2 are decimal points:

D0	0	1	0	1	0	1
D1	0	0	1	1	0	0
D2	0	0	0	0	1	1
Decimal point	x	.x	.xx	.xxx	.xxxx	.xxxxx
D3 D4 D6 0(unchanged) D5 1(unchanged)						

Additionally, D3 to D7 are as follows:

D7	D6	D6	D5	D4	D3
-----------	-----------	-----------	-----------	-----------	-----------

		Zero point	Overflow	Stable	Symbol
Fixed 0	Fixed 0	0- non-zero 1-zero	1- Overflow 0- Normal	1- Unstable 0- stable	1- Negative 0- positive

BCD1 -- 1 byte, the 1th bit of weight data,, 2th bit, BCD code, high bits in front;
BCD2 --1 byte, the 2th/3th bit of the weight data, BCD code, with the high bits in front;

Bcd3 -- 1 byte, the 5th/6th bit of the weight data, BCD code, with the high bits in front.

7.5 SP1-Cont protocol

In this mode, no commands need to be sent to the weight transmitter; the display automatically sends the collected data to the host computer.

Its data frame format:

STX	Scale No.	Channel No.	Status	Weight value	CRC	CR	LF
------------	-----------	-------------	--------	--------------	------------	-----------	-----------

Among them:

STX -- 1 byte, start character, **02H**

Scale No. - 2 bytes, ranging from **00** to **99**, followed by port number/slave number

Channel number - fixed to **31**

Status - 2 bytes, high byte: fixed to **40H**; The bits of the low byte are defined as follows

D7	D6	D5	D4	D3	D2	D1	D0
Undefined	Undefined	Undefined	Gross/net weight	Positive/Negative	Zero	Overflow	Stable
Fixed :0	Fixed : 1	Fixed :0	0: Gross weight 1: Net weight	0: Positive 1: Negative	0: Non-zero 1: Zero	0: Normal 1: Overflow	0: Stable 1: Unstable

Weight value – 6 bytes unsigned number; The lead is 0, replaced by a space. Return as "space space **OFL** space" when the weight overflow is positive (negative). Do not send decimal points, no units

CRC -- 2 bytes, checksum, see CRC calculation instructions for specific calculations.

CR -- 1 byte, **0DH**

LF - 1 byte, **0AH**

For example:

Current instrument automatically returns data: **02 30 31 31 40 41 20 20 20 37 30 30 (take the displayed weight) 32 34 0D 0A**

It is known that the current status of the instrument is stable, the weight value is positive, and the current weight value is **700**.

7.5.1 CRC calculation

Add up all the values in front of the check bit and convert to decimal data, then take the last two bits and convert to **ASCII** code (tens in front and units behind).

For example

If you have the following frame of data:

02	30	31	31	4F	43	5A	38	34	0D	0A
-----------	-----------	-----------	-----------	-----------	-----------	-----------	-----------	-----------	-----------	-----------

The sum of 02 to 5A: **180 (Hex)**, converted to decimal **384**. From this, it can be calculated that the checksum for the data frame is **38, 34**.

7.6 RE-Cont Protocol

In this mode, no commands need to be sent to the weighing display, and the display automatically sends the collected data to the upper computer.

Return data frame format description:

"Status"	,	GS/NT	,	+/-	Display value	Unit	CR	LF
2 bits	2C	47 53/4E 54	2C	2B/2D	7 bits	6B 67	0D	0A

Among them:

Status - 2 bytes, **OL**(overflow):**4FH 4CH**; **ST**(stable):**53H 54H**; **US**(unstable):**55H 53H**

Display value - 7 bytes, with decimal point, high bits are spaces if there is no decimal point

Unit - 2 bytes, such as **kg**: **6BH 67H**; **g**:**20H 67H**; **t**:**20H 74H**, etc

For example:

When the weighing display automatically sends the following frame of data:

53 54 2C 47 53 2C 2B 30 31 31 2E 31 32 30 6B 67 0D 0A

It is known that the current state is: stable, the data value is positive, and the displayed value is **11.120kg**

7.7 PROFINET communication

The instrument has two **Profinet-IO** bus connection ports, **Port1** and **Port2**, which can be connected to the **PROFINET** bus as a **Profinet-IO** slave station.

The instrument **IP address** can be set and viewed in communication parameters F3.1 and F3.2; **MAC addresses are viewed in the F9.7** parameter. Data types can be modified via F3.11.

7.7.1 IO status

The **G-2301P** provides loop parameters of **32** bytes **Input** and **14** bytes **Output** through which the master station **can read and** control the status of the weighing display. Non-cyclic parameters can use cyclic parameters to read and write instrument parameters according to modbus addresses.

PN loop parameter list

Offset	Parameter Name	Data Type	Parameter description
Weight, millivolts and status parameters (read-only, I address)			
0	Current displayed weight	DWord	Currently displayed weight integer/weight floating-point, data type displayed according to the data type selected by F3.11 . Int: Integer weight display; Float: Floating-point weight display
4	Gross weight	DWord	Current gross renormalic/gross heavy floating-point type, data type displayed according to the data type selected by F3.11 . Int: Integer weight display; Float: Floating-point weight display
8	Net weight	DWord	Current net reformed/net heavy floating-point type, data type displayed according to the data type selected in F3.11 . Int: Integer weight display; Float: Floating-point weight display
12	loadcell voltage	Real	The current loadcell voltage is of floating-point type

16	Analog	DWord	Current analog, integer value.
20	Weight status flag bit	Word	D15: Communication heartbeat
			D12-D14: Reserve
			D11: The current weight is the theoretical value
			D10: ADC failure
			D09: Currently net weight
			D08: Loadcell negative overflow, below the allowable range of loadcell voltage
			D07: Loadcell positive overflow, greater than the loadcell voltage allowable range
			D06: Weight negative overflow, weight less than "-(maximum range +9d)"
			D05: Positive weight overflow, weight greater than "maximum range +9d"
			D04: Overflow status
			D03: Display weight negative sign (Display weight as a negative number)
			D02: Zero point
			D01: Millivolt instability (the calibration bit for determining millivolt stability during calibrating)
22	Error Code 1	Word	D15: Print prohibited if print protocol is not selected
			D14: Division over-precision
			D13: Calibration lock
			D12: Unstable during calibration waiting to stabilize
			D11: Perform remote calibration when remote calibration is disabled
			D10: The previous weight point was not calibrated
			D09: Beyond minimum resolution (less than 0.1uV per division)
			D08: Weight input exceeds the maximum range
			D07: The weight input cannot be zero
			D06: Weight calibration less than zero or the previous calibration point
			D05: Loadcell positive overflowing during weight calibration
			D04: Loadcell negative overflow during weight calibration
			D03: Unstable weight calibration
			D02: loadcell positive overflow during zero calibration
D01: loadcell negative overflow during zero calibration			
D00: Unstable when zero calibration			
24	Error Code 2	Word	D05 to D15 : Reserve
			D04 : The switch is not on when automatically correcting the weight factor
			D03 : The result is less than or equal to 0 when the weight factor is automatically corrected
			D02 : Overflow when automatically correcting the weight factor
			D01 : Net weight does not allow auto correct

			weight D00: Unstable weight when automatically correcting the weight coefficient
26	Error Code 3	Word	D15: Calibration error
			D14: Unstable operation, waiting to stabilize
			D13: The tare weight operation switch is not on
			D12: Forbid tare continuously
			D11: The weight is negative when taring
			D10: Loadcell positive overflows when taring
			D09: Loadcell negative overflow during taring
			D08: Unstable during taring
			D07: Net weight status does not allow zeroing
			D06: Reserve
			D05: Loadcell Positive overflow when zeroing
			D04: Loadcell Negative overflow when zeroing
			D03: Zero unstable
			D02: Zeroing out of range
			D01: Unstable when power-on and zeroing
D00: Power-on zero out of range			
28	Read value	Dword	The master station requests the data returned by the instrument, the value obtained based on "the address requested to read"
Function operations (Write only, Q address)			
0	Function Operations	Word	D7-D15: Reserve
			D6: Print feed paper
			D5: Print
			D4: Zero point calibration
			D3: Gross/net weight switch
			D2: Clear tare
			D1: Tare
D0: Zeroing			
2	The requested value is the modbus address	DWord	Modbus write operation address (note that it will not be written if the address changes) This parameter modification interface module supports MODBUS register address range limited to 100-1307 0: Do not write data
6	Input data	DWord	The Modbus write operation value writes that data to "the modbus address of the requested value" (note that it is written to the instrument only if the value changes), and this parameter modification interface module supports MODBUS address range limited to 100-1307
10	Request to read the operation address	DWord	Modbus reads the operation address (note not to write an odd address when reading a two-word address).

7.7.2 Device Description File GSD

The device description file and connection method for **G-2301P** can be **downloaded** from the website of General Measure Technology co., LTD. (www.gmweighing.com).

Chapter 8 Error Code and Alarm Prompt

Error codes	Alarm prompt
Err01	Input out of range
Err07	Calibration lock, calibration prohibited
Err08	Calibration operations are not allowed in remote calibration protection
Err09	Division over-precision
Err10	Zero calibration is unstable
Err11	Loadcell negative overflow when zero calibration
Err12	Loadcell positive overflow when zero calibration
Err13	Weight calibration is unstable
Err14	Loadcell negative overflow when weight calibration
Err15	The weight calibration loadcell is overflowing
Err16	The voltage is less than or equal to zero point or the previous calibration point during weight calibration
Err17	The weight input cannot be zero
Err18	Weight calibration input exceeds the maximum range
Err19	Weight calibration exceeds the minimum resolution
Err20	The front point was not calibrated during weight calibration
Err21	No print protocol selected
Err22	Unstable when auto correc weight factor
Err23	Weight is net when auto correct weight factor
Err24	Weight overflow when auto correct weight factor
Err25	The result is less than 0 when auto correct weight factor
Err26	The switch is not turned on when auto correct weight factor
Err27	Auto correct weight factor out of range
Err30	Power-on zero out of range
Err31	Power-on zero is unstable
Err32	Zeroing out of range
Err33	Zeroing is unstable
Err34	Loadcell negatively overflow the when zeroing
Err35	The loadcell positively overflow when zeroing
Err36	Net weight is not allowed to zero
Err37	The tare operation switch is not turned on
Err38	Unstable when taring
Err39	Negative overflow of the loadcell when taring
Err40	The loadcell is overflowing when taring
Err41	The weight is negative when taring
Err42	Do not tare continuously
Err60	The USB drive is not connected
Err61	Usb file error
Err62	Usb file opening error
Err63	Usb upgrade check error
Err100	Input password incorrect
Err101	The password verification does not match.
Err102	Incorrect time zone settings
Err103	Incorrect date settings
Err104	Time setting error

