



GMC-P7(F8)

Touch Screen Weighing Controller

— Static Checkweighing Application



GMC-P7(F8)

Touch Screen Weighing Controller

(Static Checkweighing Application)

High-efficient, competitive Easy operation, user-friendly

GMC-P7(F8) is the high accuracy and intelligent weighing controller with 7-inch touch screen. The static checkweighing application is developed for static weighing and counting of any industry. The touch screen is intuitive and easy to operate. The new weighing filter algorithm and optimized A/D conversion speed make the weighing process more stable. A variety of industrial communication interfaces allow efficient interaction of field equipment.



(Digital Version Available)



FEATURES & FUNCTIONS



- 7-inch touch screen, intuitive display, better interaction, easy operation;
- Stainless steel, front panel IP65, strong anti-interference;
- 50 editable formulas for user switching easily;
- Support micro printer and EPSON serial printer, table head and foot is editable;
- 4 million data storage, USB for exporting data;
- Check history records by selecting time or product name;
- Cumulative batches of weights qualified can be recorded;
- Continuous taring function;
- Analog output function;
- Standard 5 IN/5 OUT I/O ports;
- Two-level filtering function dealing with data fluctuating;
- Customized boot screen;
- Multilevel user authority management (operator, administrator);

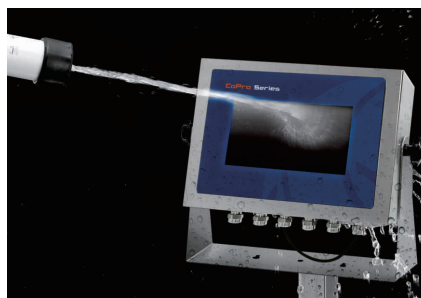

Static Weighing Function

- The weighing result is clear.



- Three tolerance modes: absolute, deviation, percentage; easy to use;

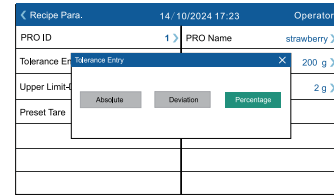

- Recording the accumulated weights and batches, easy to manage;

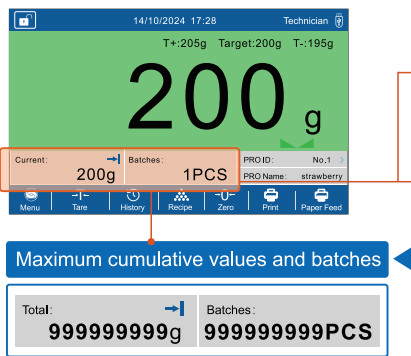

▶ When it reaches qualified weights, the total weights and batches will be record automatically.

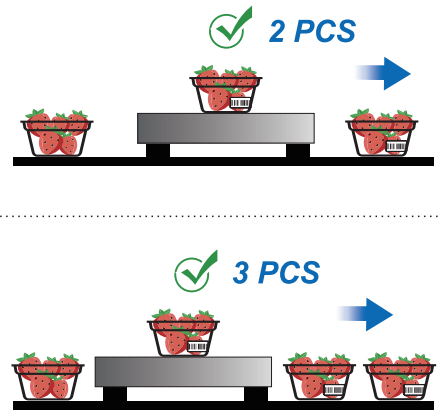
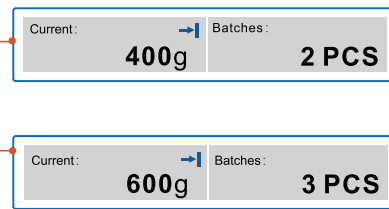

Non-target mode

Record the qualified cumulative weights and batches.

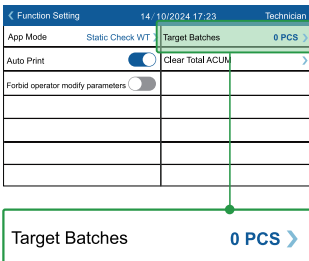

Target-mode

Reach the target weighing batch.

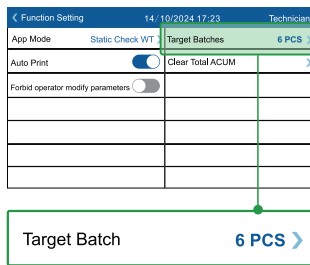

- ▶ After reaching the target batch, the completion alarm pop up, and the cumulative weights and batches will be cleared.

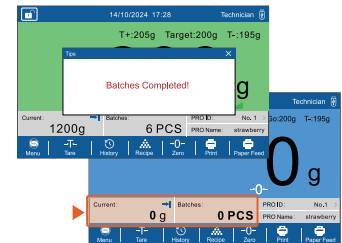

- Two-level filtering:** dealing with data fluctuating, make it stable;

- Multilevel sampling rate, more choice for user.

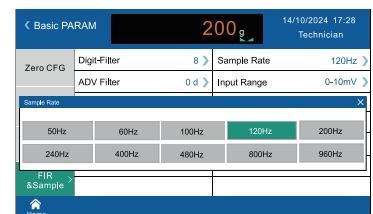

- Continuous taring;

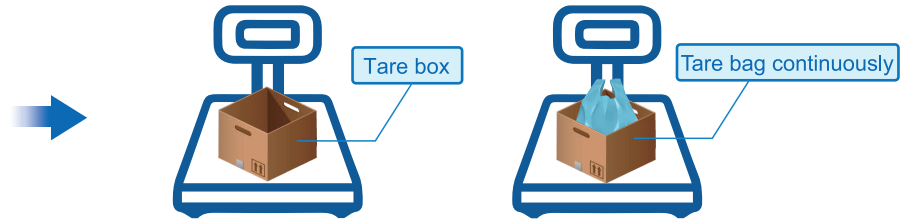
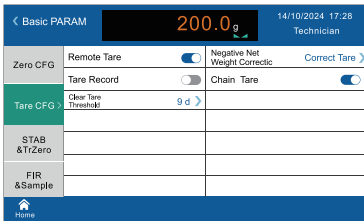

Formula Function

Recipe Param		14/10/2024 17:23		Operator	
PRO ID	1	PRO Name	strawberry		
Tolerance Entry	Deviation	Target Value	5 g		
Upper Limit-Deviation	5 g	Lower Limit-Deviation	5 g		
Preset Tare	5 g				

Recipe selection		14/10/2024 17:23		Operator	
Recipe number	PRO Name	Target Value	Upper Limit -Absolute	Lower Limit -Absolute	Preset Tare
No.1	strawberry	200g	205g	195g	10g
No.2	cherry	500g	505g	495g	15g
No.3	bread	800g	805g	795g	5g
No.4	apple	1000g	1005g	995g	10g
No.5	orange	500g	510g	490g	16g
No.6	avocado	500g	505g	495g	13g

- 50 formulas setting:
each formula has a corresponding number, name, and supports three tolerance modes.

History Record Function

- 4 million history records, including serial number, formula name, time, weighing result, target value, upper limit, lower limit.

History Data		14/10/2024 17:28		Technician	
Date Export By USB	Number	Recipe name	Time	Weight Result	Target Value
	1	strawberry	2024-10-14 15:02	205g	200g
	2	strawberry	2024-10-14 15:06	195g	200g
	3	strawberry	2024-10-14 15:08	198g	200g
	4	cherry	2024-10-14 16:12	501g	500g
	5	cherry	2024-10-14 16:19	497g	500g
	6	cherry	2024-10-14 16:27	505g	500g

Check history records by selecting the filter of time

Time Filter: Filter Start Time: 2024-10-14 15:02:00 Filter End Time: 2024-10-14 15:08:00

PRO Name Filter: PRO Name: strawberry

Check history records by selecting the filter of product name

Time Filter: Filter Start Time: 2024-10-14 16:12:00 Filter End Time: 2024-10-14 16:27:00

PRO Name Filter: PRO Name: cherry

- USB for exporting the history data;

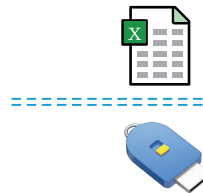
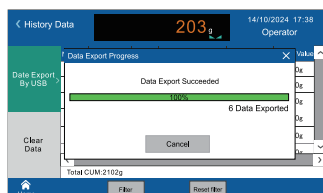

Filter Time	Filter Recipe name	Filter Weight Result	Filter Target Value	Filter Upper Limit Value	Filter Lower Limit Value
2024-10-14 15:02	strawberry	205g	200g	205g	195g
2024-10-14 15:06	strawberry	195g	200g	205g	195g
2024-10-14 15:08	strawberry	198g	200g	205g	195g
2024-10-14 16:12	cherry	501g	500g	505g	495g
2024-10-14 16:19	cherry	497g	500g	505g	495g
2024-10-14 16:27	cherry	505g	500g	505g	495g

Printing Function

- Support micro printer and EPSON serial printer, table head and foot is editable;
Available for Chinese/English printing, simple/standard format printing;

Simple format

```

            ---strawberry---
            Date      14/10/2024
            Time      15:45:00
            TNO.      62
            Net       +503 g

            Check      HI
            Sum       10693 g
            Batches   44PCS

            general-measure-
```

Standard format

```

            ---strawberry---
            Date      14/10/2024
            Time      15:45:00
            TNO.      62
            Gross     +503 g
            Net       +503 g
            Tare      +0 g

            Check      HI
            Tareget    +500 g
            Tol_H     +3 g
            Tol_L     +3 g
            Entry     Deviation
            Sum       10693 g
            Batches   44PCS

            general-measure-
```

I/O Function

- Standard 5 inputs 5 outputs I/O ports, optional 4 relay outputs;
- Support I/O testing functions;

Boot Screen Function

www.gmweighing.com

User Management

- **Two-level authority**, support admin to manage operator behavior.

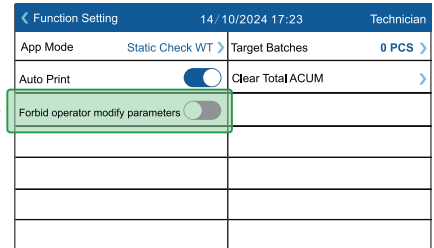
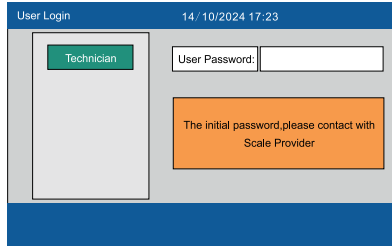

HARDWARE CONFIGURATION



Standard:

- 5 input (TTL), 5 output (TTL), I/O position can be customized;
- 2 RS485 and 1 RS232;

Options:

- Modbus TCP;
- Profinet or Ethernet/IP;
- 1 analog output;
- 4 relay output;

Digital Version

Standard:

- RS485+ RS232;
- 1 RS485 for digital loadcell interface;
- 5 inputs 5 outputs I/O;
- USB for software upgrading;

Options:

- Analog output;
- ModbusTCP or Ethernet/IP or Profinet;

Dimension

Unit:mm

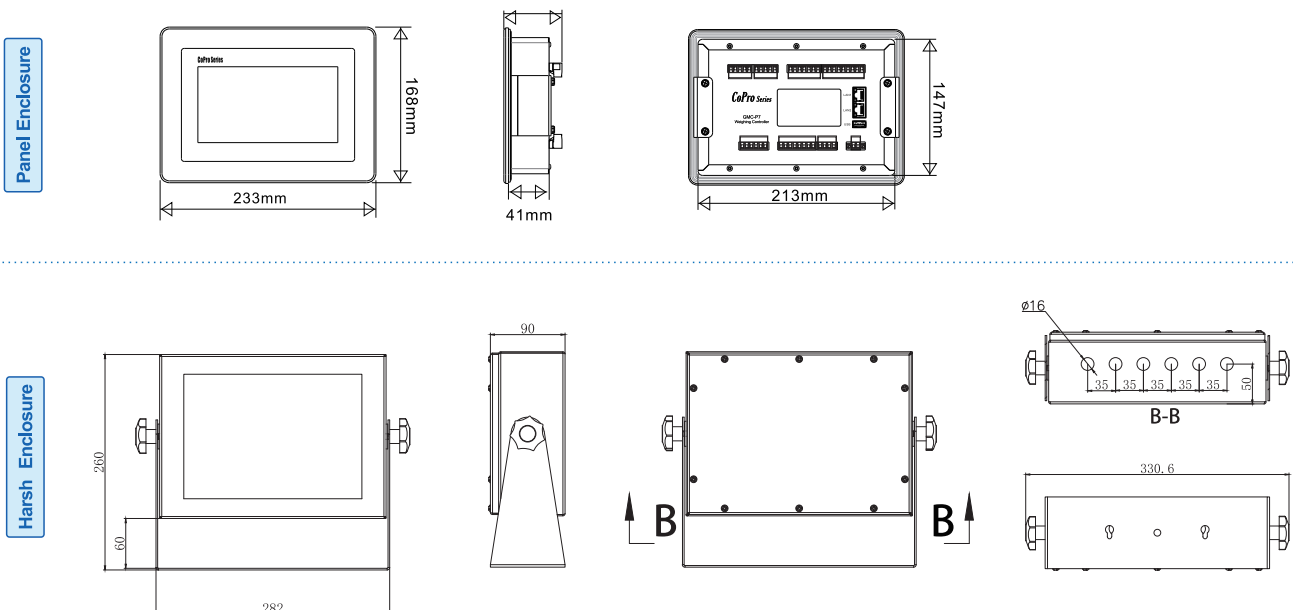

Standard Specification

	Model	GMC-P7 F8	GMC-P7 F8 Digital Version
General Specifications	Power Supply	DC 24V±5%	
	Working temperature	-10°C~40°C	
	Maximum humidity	90% RH.without dew	
	Testing standards	Class III 6000 e,1μV/d	
	Power consumption	About 15W	
	Measurement Parameters	A/D performance	24 bit Delta-Sigma
A/D conversion speed		50~960 times/per second	N/A
Non-linearity		0.01%F.S	N/A
Gain drift		10PPM/°C	N/A
Input sensitivity		0.02μV/d	N/A
Input range		0.02~15mV	N/A
Display Accuracy		1/100,000	1/100,000
Sensor power supply		DC 5V 125mA(Max)	DC 12V 250mA
Input impedance		10MΩ	N/A
Zero steady range		Maximum 0.002 ~ 15mV(Load Cell 3mV/V)	N/A

Application

Underweight Adding materials until the weight is qualified;
Qualified weight Recording the weight and batch;
Overweight Reducing materials until the weight is qualified;

Printer
Remote display
Tower light
Weighing scale

- Available to connect external devices.
- Available for weighing and counting different types of materials for industry or food retailing markets.



General Measure Technology Co.,Ltd.

Address: Room2208, Block A, Building 6, Shenzhen International Innovation Valley,
Nanshan District, Shenzhen, Guangdong Province, P.R.China.
Tel/Wechat: +86 185 6585 5789
E-mail: xjlv@szgmt.com
Website: www.gmweighing.com



Linkedin



Facebook



Wechat